



## PRODUCT LISTING SCHEME

Certificate Number : **STL-COC-Z0003**

This Certificate is awarded to the following product(s) which has / have complied with the requirements of the listed standard(s).

**Applicant** : **Liang Chew Hardware Pte Ltd**

133 Kitchener Road  
Singapore 208517

**Product** : **Epoxy Coated Cast Iron Pipe and Fittings**

**Brand / Model** : **Norika / PIPHUBEPC & HUBEPC**

**Detail** : **Nominal sizes (mm): 50, 75, 100, 150, 200 & 250**

**Test Standard(s)** : **BS EN 877: 1999 + A1 (2006), DIN EN 877: 2010, BS EN ISO 11925 - 2: 2010, BS EN 13823: 2010**

**Product conformity Certificates are awarded on the basis of an assessment of the following type-test report(s):**

2222084/01-OYC, 1920480-OYC, 1820252/01-OYC, 1820252/02-OYC, 7191039761-MEC12-01-CYW, 7191039761-MEC12-02-CYW, 7191039761-MEC12/5/1-JV, 7191039761-MEC12/5/2-JV, 7191039761-MEC12/5/3-JV, 7191039761-MEC12/04-LAS, 7191039761-MEC12/5/4-LGJ, 7191039761-MEC12-03-KCY

**Date of Original Issue** : **28-Dec-2018**

**Date of Last Revision** : **25 Nov 2022**

**Date of Expiry** : **27-Dec-2024**

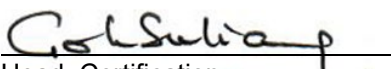
  
Head, Certification  
Singapore Test Lab Pte Ltd

Page 1 of 1

This Certificate is part of a full report and should be read in conjunction with it. This Certificate remains the property of Singapore Test Lab Pte Ltd and shall be returned upon request. The use of this Certificate is subjected to the Terms and Conditions of Singapore Test Lab Pte Ltd. The manufacturer is solely responsible for the compliance of any product that has the same designation as the product type-tested.



Singapore Test Lab Pte Ltd certifies according to ISO / IEC 17065



# EPOXY COATED HUBLESS PIPE

COMPLY WITH EN877:2010 01

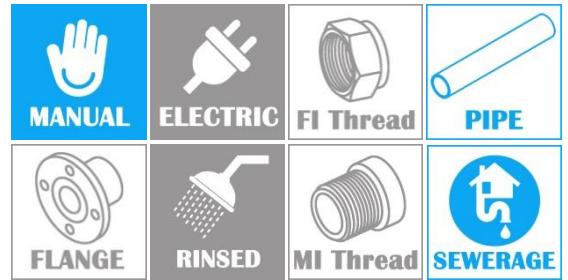

**norika** EN877 DN100x3000mm 240µm 24/07/21

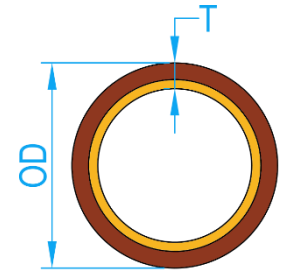
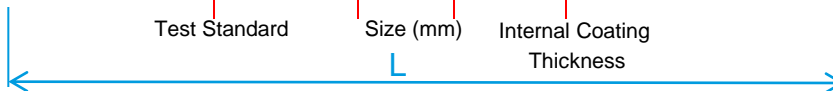

CROSS SECTIONAL VIEW

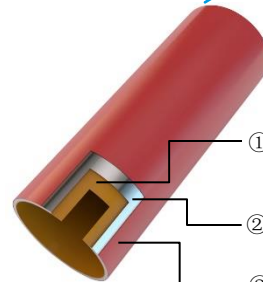

- ① Internal epoxy resin coating with high Quality properties (240µm~ 280µm)
- ② Grey Cast Iron
- ③ High quality primer External coating (80µm ~ 100µm)

## COATING CHARACTERISTIC

### Pipes:

- The inner wall of the tube: two-component epoxy resins consists of a resin and a hardener component.
- The outer wall of the tube: The senior red iron alkyl enamel coating.

## COMPONENT PARTS

ITEM	LAYERS	THICKNESS
1	External Coating	80~100µm
2	Cast Iron	EN1561
3	Internal Coating	240~280µm

\* Availability upon request.

## DIMENSIONS

SKU	DN (mm)	OD MAX (mm)	OD MIN (mm)	T- NOMINAL (mm)	T- MIN (mm)	L [mm]	WEIGHT (kg)
PIPHUB050EPC240	50	60.0	57.0	3.5	3.0	3000	13.0
PIPHUB080EPC240	75	85.0	82.0	3.5	3.0	3000	18.9
PIPHUB100EPC240	100	112.0	109.0	3.5	3.0	3000	25.2
PIPHUB125EPC240	125*	137.0	133.0	4.0	3.5	3000	35.4
PIPHUB150EPC240	150	162.0	158.0	4.0	3.5	3000	42.2
PIPHUB200EPC240	200	212.0	208.0	5.0	4.0	3000	69.3
PIPHUB250EPC240	250*	276.5	271.5	5.5	4.5	3000	99.8
PIPHUB300EPC240	300*	328.5	323.5	6.0	5.0	3000	129.7

# EPOXY COATED HUBLESS PIPE

COMPLY WITH EN877:2010 01

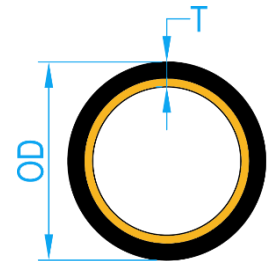
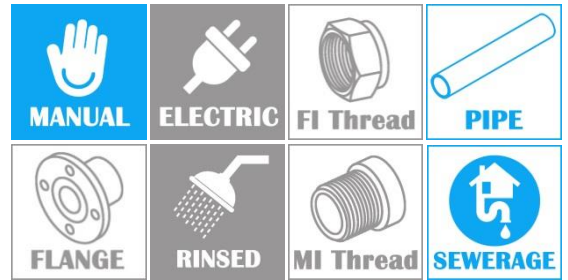

CROSS SECTIONAL VIEW

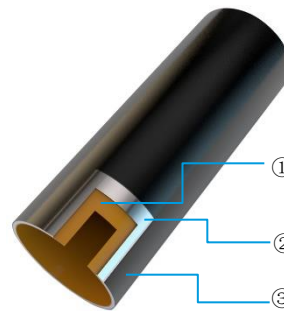
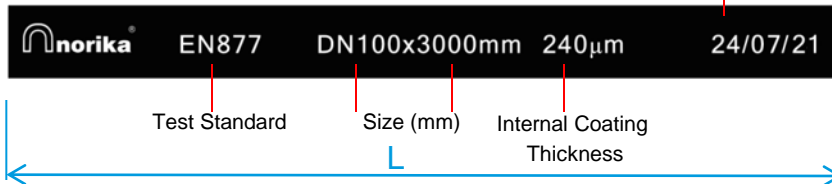

- ① Internal epoxy resin coating with high Quality properties (240µm~ 280µm)
- ② Grey Cast Iron
- ③ High quality primer External coating (80µm ~ 100µm)

## COATING CHARACTERISTIC

### Pipes:

- The inner wall of the tube: two-component epoxy resins consists of a resin and a hardener component.
- The outer wall of the tube: The senior red iron alkyd enamel coating.

## COMPONENT PARTS

ITEM	LAYERS	THICKNESS
1	External Coating	80~100µm
2	Cast Iron	EN1561
3	Internal Coating	240~280µm

\* Availability upon request.

## DIMENSIONS

SKU	DN (mm)	OD MAX (mm)	OD MIN (mm)	T- NOMINAL (mm)	T- MIN (mm)	L [mm]	WEIGHT (kg)
PIPHUB050EPCB240	50	60.0	57.0	3.5	3.0	3000	13.0
PIPHUB080EPCB240	75	85.0	82.0	3.5	3.0	3000	18.9
PIPHUB100EPCB240	100	112.0	109.0	3.5	3.0	3000	25.2
PIPHUB125EPCB240	125*	137.0	133.0	4.0	3.5	3000	35.4
PIPHUB150EPCB240	150	162.0	158.0	4.0	3.5	3000	42.2
PIPHUB200EPCB240	200	212.0	208.0	5.0	4.0	3000	69.3
PIPHUB250EPCB240	250*	276.5	271.5	5.5	4.5	3000	99.8
PIPHUB300EPCB240	300*	328.5	323.5	6.0	5.0	3000	129.7

# EPOXY COATED HUBLESS PIPE

COMPLY WITH EN877:2010 01

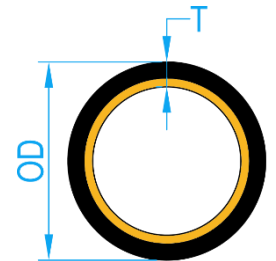
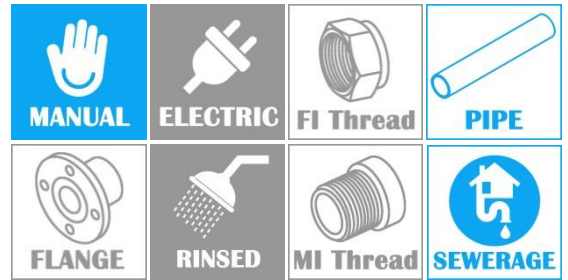

CROSS SECTIONAL VIEW

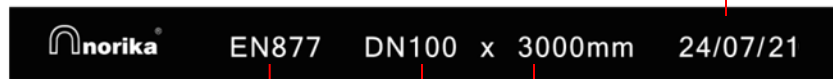

Test Standard      Size (mm)



Manufacturing Date



- ① Internal epoxy resin coating with high Quality properties (Min- 120µm)
- ② Grey Cast Iron
- ③ High quality primer External coating (80µm ~ 100µm)

## COATING CHARACTERISTIC

### Pipes:

- The inner wall of the tube: two-component epoxy resins consists of a resin and a hardener component.
- The outer wall of the tube: The senior red iron alkyd enamel coating.

## COMPONENT PARTS

ITEM	LAYERS	THICKNESS
1	External Coating	80~100µm
2	Cast Iron	EN1561
3	Internal Coating	Min- 120µm

\* Availability upon request.

## DIMENSIONS

SKU	DN (mm)	OD MAX (mm)	OD MIN (mm)	T- NOMINAL (mm)	T- MIN (mm)	L [mm]	WEIGHT (kg)
PIPHUB050EPCB	50	60.0	57.0	3.5	3.0	3000	13.0
PIPHUB080EPCB	75	85.0	82.0	3.5	3.0	3000	18.9
PIPHUB100EPCB	100	112.0	109.0	3.5	3.0	3000	25.2
PIPHUB125EPCB	125*	137.0	133.0	4.0	3.5	3000	35.4
PIPHUB150EPCB	150	162.0	158.0	4.0	3.5	3000	42.2
PIPHUB200EPCB	200	212.0	208.0	5.0	4.0	3000	69.3
PIPHUB250EPCB	250*	276.5	271.5	5.5	4.5	3000	99.8
PIPHUB300EPCB	300*	328.5	323.5	6.0	5.0	3000	129.7

# EPOXY COATED HUBLESS PIPE

COMPLY WITH EN877:2010 01

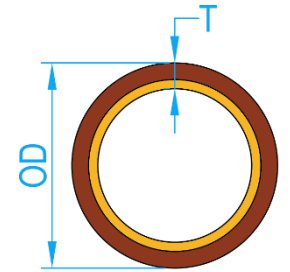
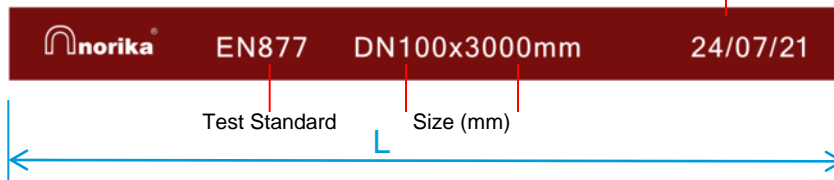
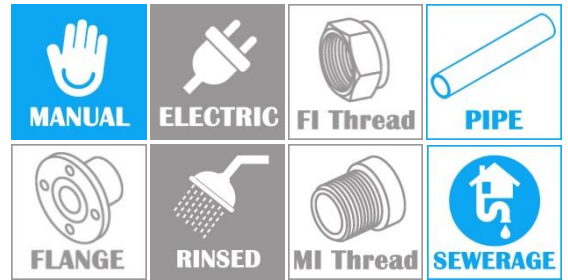

CROSS SECTIONAL VIEW

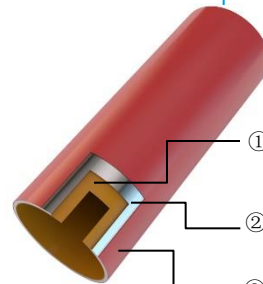

- ① Internal epoxy resin coating with high Quality properties (Min- 120µm)
- ② Grey Cast Iron
- ③ High quality primer External coating (80µm ~ 100µm)

## COATING CHARACTERISTIC

### Pipes:

- The inner wall of the tube: two-component epoxy resins consists of a resin and a hardener component.
- The outer wall of the tube: The senior red iron alkyd enamel coating.

## COMPONENT PARTS

ITEM	LAYERS	THICKNESS
1	External Coating	80~100µm
2	Cast Iron	EN1561
3	Internal Coating	Min-120µm

\* Availability upon request.

## DIMENSIONS

SKU	DN (mm)	OD MAX (mm)	OD MIN (mm)	T- NOMINAL (mm)	T- MIN (mm)	L [mm]	WEIGHT (kg)
PIPHUB050EPC	50	60.0	57.0	3.5	3.0	3000	13.0
PIPHUB080EPC	75	85.0	82.0	3.5	3.0	3000	18.9
PIPHUB100EPC	100	112.0	109.0	3.5	3.0	3000	25.2
PIPHUB125EPC	125*	137.0	133.0	4.0	3.5	3000	35.4
PIPHUB150EPC	150	162.0	158.0	4.0	3.5	3000	42.2
PIPHUB200EPC	200	212.0	208.0	5.0	4.0	3000	69.3
PIPHUB250EPC	250*	276.5	271.5	5.5	4.5	3000	99.8
PIPHUB300EPC	300*	328.5	323.5	6.0	5.0	3000	129.7

# FUSION BONDED EPOXY COATED HUBLESS SHORT PIPE WITH ACCESS DOOR & BEND & CROSS TEE

COMPLY WITH EN877:2010 01

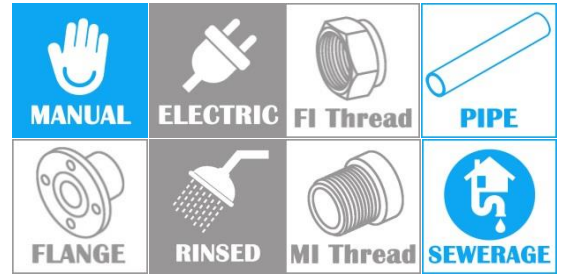

## COATING CHARACTERISTIC

### Fittings:

Epoxy fittings inside and outside: Fusion bonded epoxy coating.

Coating Thickness: Min- 240µm

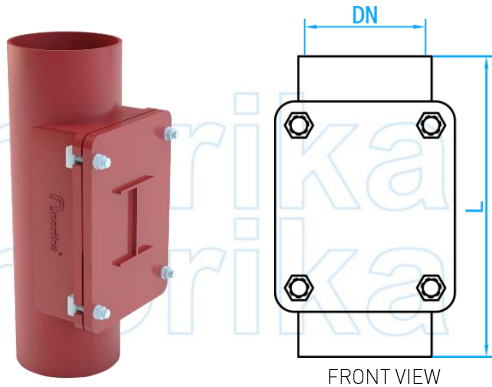

SHORT PIPE WITH ACCESS DOOR

## DIMENSIONS

SKU	DN (mm)	L (mm)	WEIGHT (kg)
HUBSP080EPC	75	220	2.3
HUBSP100EPC	100	340	7.6
HUBSP150EPC	150	395	14.5
HUBSP200EPC	200	465	22.0
HUBSP250EPC	250	575	36.5

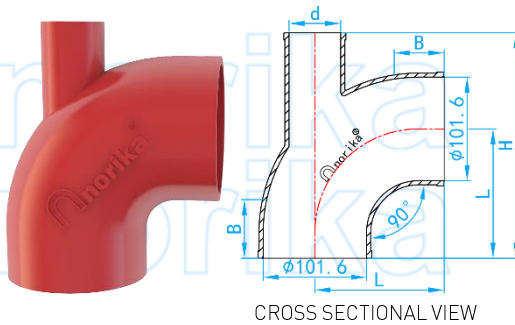

4"x2"x90 DEG BEND

## DIMENSIONS

SKU	SIZE (mm)	B (mm)	L (mm)	d (mm)	H (mm)	WEIGHT (kg)
HUBB9010050EPC	100X50	35	125	50.8	218	2.50



CROSS TEE 88°

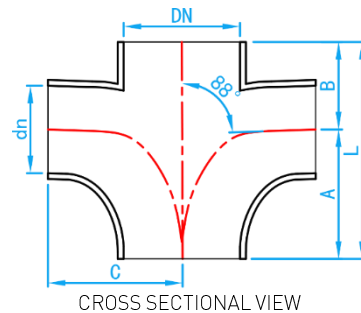

## DIMENSIONS

SKU	DN (mm)	dn (mm)	A (mm)	B (mm)	L (mm)	C (mm)	WEIGHT (kg)
HUBCT10050EPC	100	50	100	80	180	105	2.2
HUBCT100100EPC	100	100	120	110	230	120	3.2
HUBCT150100EPC	150	100	130	115	245	145	7.1



# FUSION BONDED EPoxy COATED HUBLESS CAP & REDUCER

COMPLY WITH EN877:2010 01

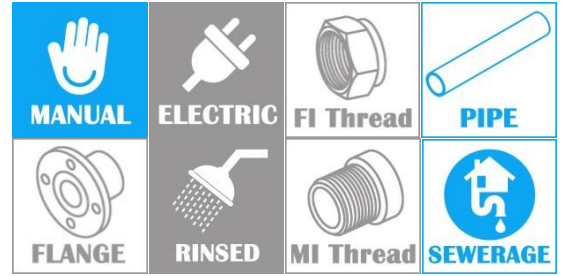

END CAP

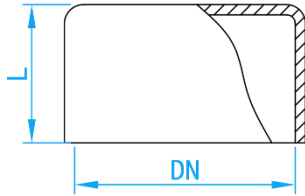

CROSS SECTIONAL VIEW

REDUCER

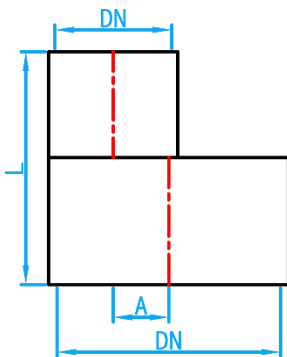

SIDE VIEW

## COATING CHARACTERISTIC

### Fittings:

Epoxy fittings inside and outside: Fusion bonded epoxy coating.

Coating Thickness: Min- 240µm

### DIMENSIONS

SKU	DN (mm)	L (mm)	WEIGHT (kg)
HUBEC050EPC	50	30	0.2
HUBEC080EPC	75	35	0.5
HUBEC100EPC	100	40	0.8
HUBEC150EPC	150	50	1.7
HUBEC200EPC	200	60	3.1
HUBEC250EPC	250	70	6.0

### DIMENSIONS

SKU	DN (mm)	L (mm)	A (mm)	WEIGHT (kg)
HUBRS08050EPC	75X50	75	12.5	0.7
HUBRS10050EPC	100X50	80	25	0.9
HUBRS10080EPC	100X75	100	13.5	1.1
HUBRS12550EPC	125X50	85	38.5	1.4
HUBRS12580EPC	125X75	95	26	1.7
HUBRS125100EPC	125X100	95	12.5	1.8
HUBRS15050EPC	150X50	95	51	2.0
HUBRS15080EPC	150X75	100	37.5	2.1
HUBRS150100EPC	150X100	150	25	2.2
HUBRS150125EPC	150X125	110	12.5	2.2
HUBRS20080EPC	200X75	115	62.5	3.15
HUBRS200100EPC	200X100	115	50	4.1
HUBRS200125EPC	200X125	120	37.5	4.2
HUBRS200150EPC	200X150	125	25	4.3
HUBRS250100EPC	250X100	130	75	6.2
HUBRS250150EPC	250X150	140	57	6.8
HUBRS250200EPC	250X200	145	32	7.0
HUBRS300150EPC	300X150	150	83	10.7
HUBRS300200EPC	300X200	160	58	11.4
HUBRS300250EPC	300X250	170	26	12.4

\*Availability upon request

# FUSION BONDED EPOXY COATED HUBLESS BEND

COMPLY WITH EN877:2010 01

## COATING CHARACTERISTIC

### Fittings:

Epoxy fittings inside and outside: Fusion bonded epoxy coating.

Coating Thickness: Min- 240µm

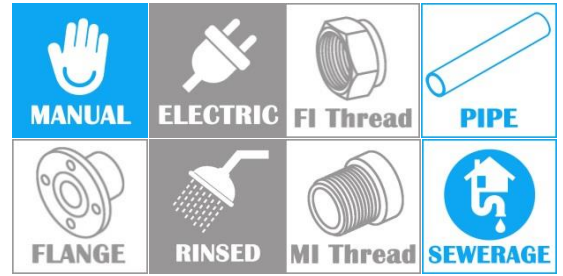

\*Availability upon request

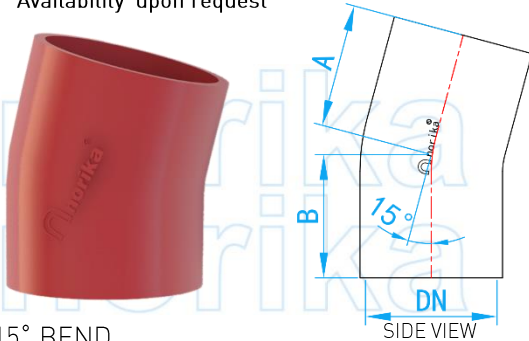

15° BEND

### DIMENSIONS

SKU	DN (mm)	A (mm)	B (mm)	WEIGHT (kg)
HUBB15050EPC	50	40	40	0.6
HUBB15080EPC	75	50	50	0.8
HUBB15100EPC	100	50	50	1.0
HUBB15125EPC	125*	60	60	1.7
HUBB15150EPC	150	65	65	2.5
HUBB15200EPC	200	80	80	4.6

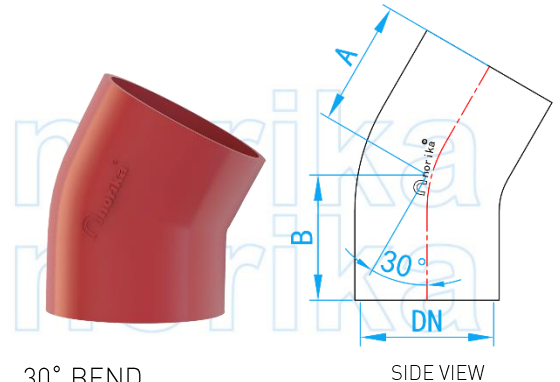

30° BEND

### DIMENSIONS

SKU	DN (mm)	A (mm)	B (mm)	WEIGHT (kg)
HUBB30050EPC	50	45	45	0.5
HUBB30080EPC	75	60	60	0.8
HUBB30100EPC	100	60	60	1.3
HUBB30125EPC	125*	70	70	2.0
HUBB30150EPC	150	80	80	3.0
HUBB30200EPC	200	95	95	5.4
HUBB30250EPC	250	110	110	9.7
HUBB30300EPC	300	130	130	15.5

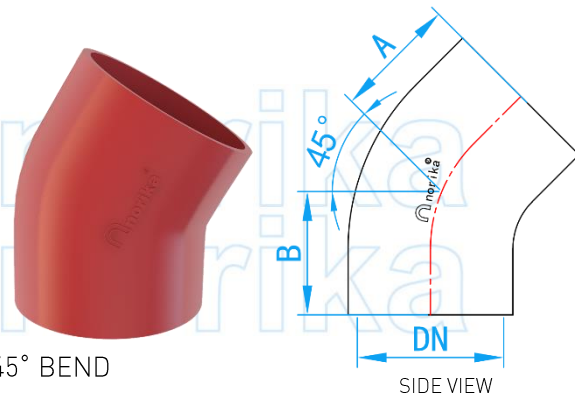

45° BEND

### DIMENSIONS

SKU	DN (mm)	A (mm)	B (mm)	WEIGHT (kg)
HUBB45050EPC	50	60	60	0.5
HUBB45080EPC	75	60	60	1.0
HUBB45100EPC	100	70	70	1.6
HUBB45125EPC	125*	80	80	2.3
HUBB45150EPC	150	90	90	3.5
HUBB45200EPC	200	110	110	6.2
HUBB45250EPC	250	130	130	10.3
HUBB45300EPC	300	155	155	17.3

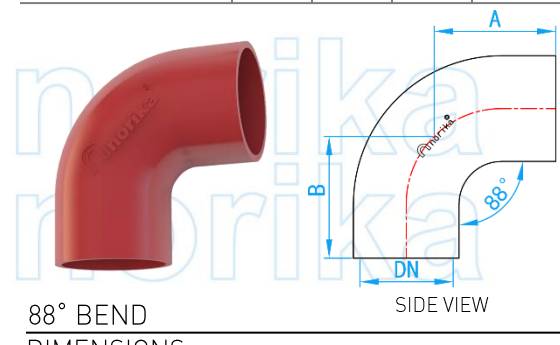

88° BEND

### DIMENSIONS

SKU	DN (mm)	A (mm)	B (mm)	WEIGHT (kg)
HUBB90050EPC	50	75	75	0.7
HUBB90080EPC	75	95	95	1.4
HUBB90100EPC	100	110	110	2.1
HUBB90125EPC	125*	125	125	3.2
HUBB90150EPC	150	145	145	4.9
HUBB90200EPC	200	180	180	8.8
HUBB90250EPC	250	225	225	17.9
HUBB90300EPC	300	260	260	28.0



# FUSION BONDED EPOXY COATED HUBLESS BRANCH TEE 88°

COMPLY WITH EN877:2010 01

\*Availability upon request

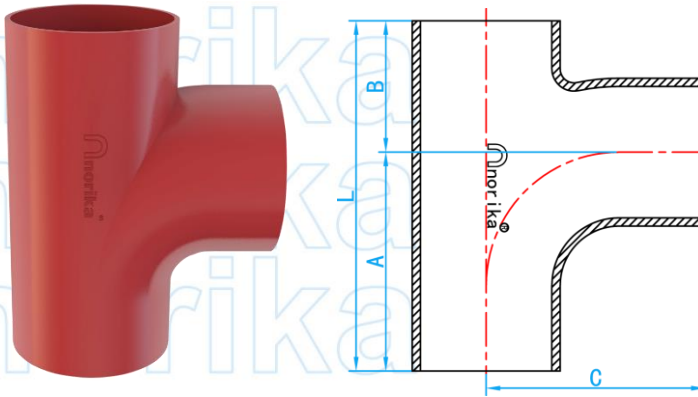

CROSS SECTIONAL VIEW

## COATING CHARACTERISTIC

### Fittings:

 Epoxy fittings inside and outside:  
Fusion bonded epoxy coating.

Coating Thickness: Min- 240µm

## DIMENSIONS

SKU	DN (mm)	A (mm)	B (mm)	L (mm)	C (mm)	WEIGHT (kg)
HUBET050EPC	50X50	79	66	145	80	0.9
HUBRT08050EPC	75X50	95	85	180	90	1.6
HUBET080EPC	75X75	95	85	180	90	1.9
HUBRT10050EPC	100X50	94	76	170	105	2.1
HUBRT10080EPC	100X75	105	90	195	110	2.6
HUBET100EPC	100X100	115	105	220	120	2.9
HUBRT12550EPC	125X50*	98	82	180	120	3.0
HUBRT12580EPC	125X75*	110	94	205	125	3.4
HUBRT125100EPC	125X100*	125	110	235	130	4.0
HUBRT15050EPC	150X50	100	100	200	140	4.4
HUBRT15080EPC	150X75	110	110	220	145	5.0
HUBRT150100EPC	150X100	130	115	245	145	5.5
HUBRT150125EPC	150X125*	147	128	275	150	6.2
HUBET150EPC	150X150	158	142	300	155	6.9
HUBRT200100EPC	200X100	144	126	270	175	7.8
HUBRT200150EPC	200X150	173	152	325	185	10.8
HUBET200EPC	200X200	202	178	380	195	12.8
HUBRT250100EPC	250X100	165	147	312	210	18.2
HUBRT250150EPC	250X150	195	160	355	230	19.3
HUBRT250200EPC	250X200	205	200	405	240	21.0
HUBET250EPC	250X250	250	220	470	240	24.5
HUBET300EPC	300X300	300	266	566	300	38.0

# FUSION BONDED EPOXY COATED HUBLESS BRANCH TEE 45°

COMPLY WITH EN877:2010 01

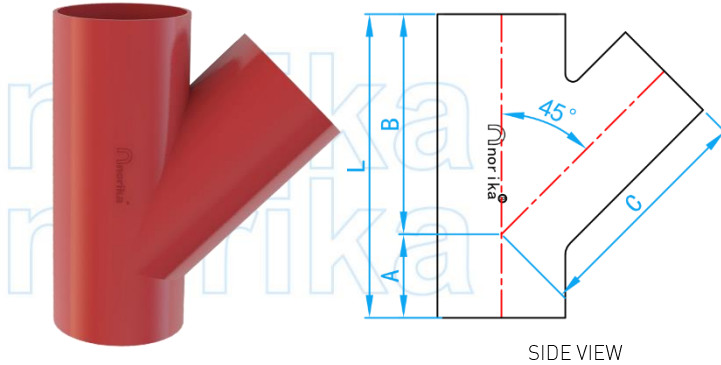
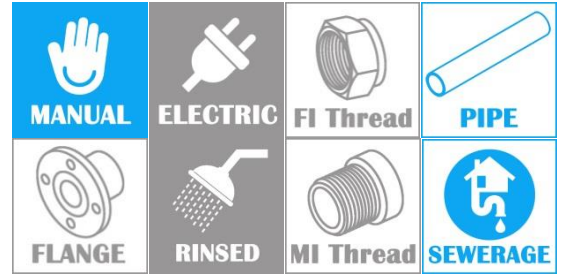

### COATING CHARACTERISTIC

**Fittings:**

Epoxy fittings inside and outside: Fusion bonded epoxy coating.

Coating Thickness: Min- 240µm

\*Availability upon request

### DIMENSIONS

SKU	DN (mm)	A (mm)	B (mm)	L (mm)	C (mm)	WEIGHT (kg)
HUBYT050EPC	50X50	50	135	185	135	1.4
HUBYT08050EPC	75X50	50	140	190	140	1.8
HUBYT080EPC	75X75	65	160	225	160	2.4
HUBYT10050EPC	100X50	35	165	200	165	2.5
HUBYT10080EPC	100X75	55	175	230	175	3.3
HUBYT100EPC	100X100	70	205	275	205	4.2
HUBYT12550EPC	125X50*	20	185	205	185	3.4
HUBYT12580EPC	125X75*	40	200	240	200	4.4
HUBYT125100EPC	125X100	60	220	208	220	5.2
HUBYT15080EPC	150X75	30	215	345	215	5.9
HUBYT150100EPC	150X100	55	240	295	240	6.8
HUBYT150125EPC	150X125*	70	255	325	255	8.0
HUBYT150EPC	150X150	90	265	355	265	9.2
HUBYT20080EPC	200X75	15	240	255	240	8.5
HUBYT200100EPC	200X100	40	265	305	265	10.0
HUBYT200125EPC	200X125*	55	280	335	280	11.9
HUBYT200150EPC	200X150	75	300	375	300	13.3
HUBYT200EPC	200X200	115	340	455	340	17.2
HUBYT250100EPC	250X100*	15	310	325	310	15.4
HUBYT250125EPC	250X125*	35	335	370	335	17.7
HUBYT250150EPC	250X150*	55	350	405	350	20.2
HUBYT250200EPC	250X200*	90	385	475	385	25.1
HUBYT250EPC	250X250*	130	430	560	430	31.5
HUBYT300100EPC	300X100*	5	345	350	345	22.0
HUBYT300125EPC	300X125*	15	360	375	360	23.9
HUBYT300150EPC	300X150*	35	380	415	380	26.9
HUBYT300200EPC	300X200*	70	415	485	415	34.0
HUBYT300250EPC	300X250*	115	465	580	465	34.0
HUBYT300EPC	300X300*	155	505	660	505	50.1

# FUSION BONDED EPOXY COATED HUBLESS TRAPS

COMPLY WITH EN877:2010 01

## COATING CHARACTERISTIC

### Fittings:

Epoxy fittings inside and outside: Fusion bonded epoxy coating.

Coating Thickness: Min- 240µm

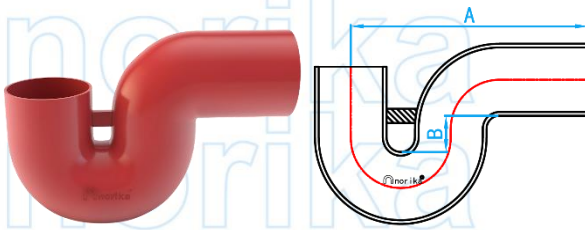
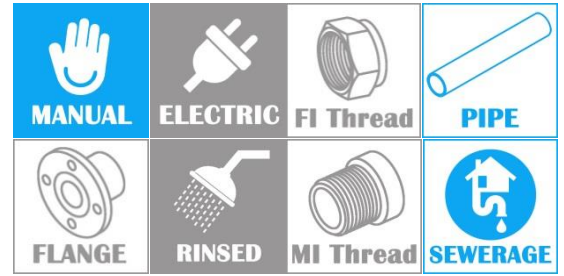

CROSS SECTIONAL VIEW

P-TRAP  
(100mmx100mm)

### DIMENSIONS

SKU	A (mm)	B (mm)	WEIGHT (kg)
HUBPT100EPC	358.5	53.5	7.40

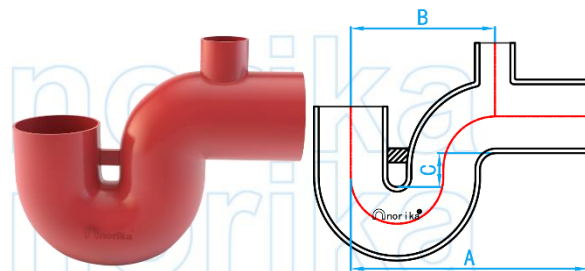

CROSS SECTIONAL VIEW

P-TRAP  
(100mmx100mmx50mm)

### DIMENSIONS

SKU	A (mm)	B (mm)	C (mm)	WEIGHT (kg)
HUBPT10050EPC	358.5	225	53.5	7.80

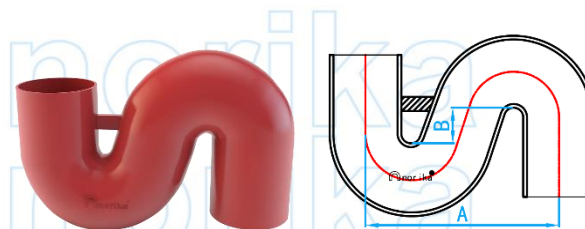

CROSS SECTIONAL VIEW

S-TRAP  
(100mmx100mm)

### DIMENSIONS

SKU	A (mm)	B (mm)	WEIGHT (kg)
HUBST100EPC	305	55.7	7.40

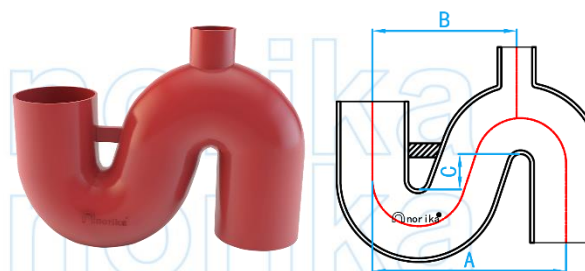

CROSS SECTIONAL VIEW

S-TRAP  
(100mmx100mmx50mm)

### DIMENSIONS

SKU	A (mm)	B (mm)	C (mm)	WEIGHT (kg)
HUBST10050EPC	305	228	55.7	8.80

# STAINLESS STEEL 304 TYPE A HUBLESS CLIPS

COMPLY WITH CISPI 310-12  
EN 877:2010

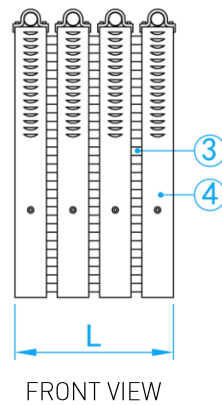
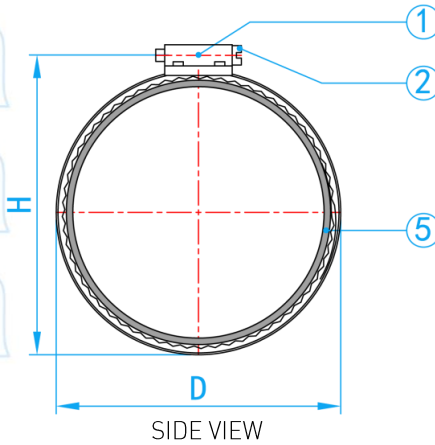
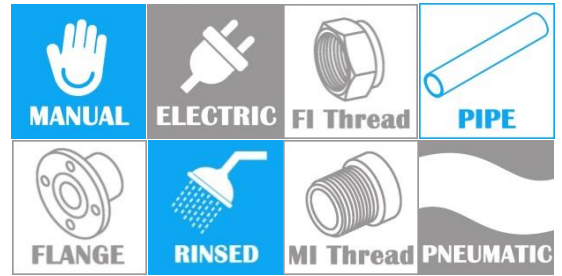

INSTALLATION ASSEMBLY

COMPONENT PARTS

ITEM	PARTS	MATERIAL
1	Housing	AISI304
2	Worm Screw	AISI304
3	Worm Drive Band	AISI304
4	Shield	AISI304
5	Gasket	EPDM

STANDARD SPECIFICATIONS

SKU	SIZE (mm)	Shield With L (mm)	Shield Thickness (mm)	Clamp Width (mm)	No. Clamps	H (mm)	D (mm)	Bolt Size (inch)	Pressure (BAR)	Install Torque (Nm)	Weight (kg)	PCS/CTN
HUBC050	50	54	0.18	14.2	2	81.2	72	SS304 5/16 Slotted Hex Head worm Screw	0.5	7.5	0.13	100
HUBC080	75	54			2	105.7	96.5				0.16	100
HUBC100	100	54			2	130	121				0.20	100
HUBC150	150	76			4	184	175				0.47	50
HUBC200	200	100			4	239	230				0.69	30
HUBC250	250	100			4	309	300				0.86	20
HUBC300	300	138			6	359	350				1.54	16

# STAINLESS STEEL TYPE A REDUCING HUBLESS CLIPS

COMPLY WITH CISPI 310-2012  
EN877:2010

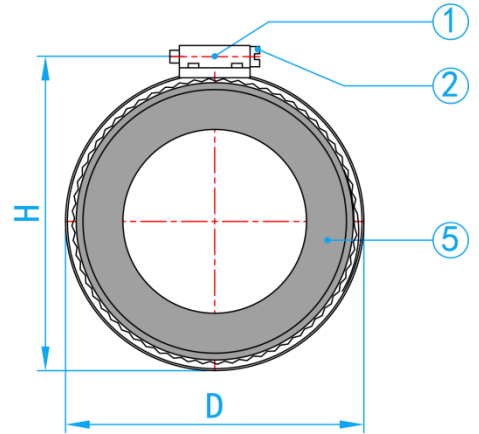
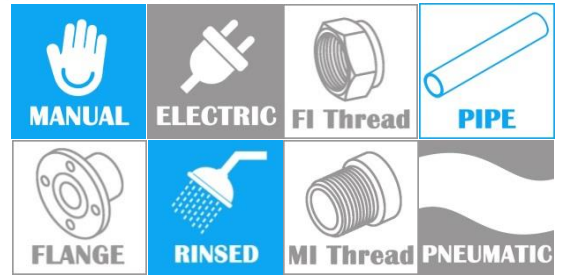

SIDE VIEW

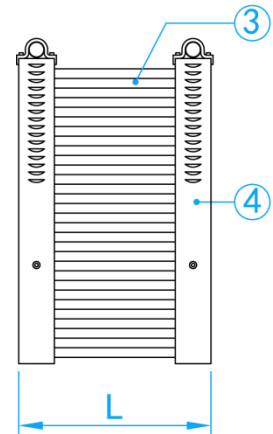

FRONT VIEW

INSTALLATION ASSEMBLY

### COMPONENT PARTS

ITEM	PARTS	MATERIAL
1	Housing	Stainless Steel 304
2	Worm Screw	Stainless Steel 304
3	Worm Drive Band	Stainless Steel 304
4	Shield	Stainless Steel 304
5	Gasket	EPDM

### STANDARD SPECIFICATIONS

SKU	SIZE (mm)	L (mm)	H (mm)	D (mm)	BOLT	BAR	Install Torque (Nm)	WEIGHT (kg)	PCS/CTN
HUBC05042	50 x 42	54	81.2	72	SS304 5/16 Slotted Hex Head Worm Screw	0.5	7.5	0.15	100
HUBC08050	75 x 50	54	105.7	96.5	SS304 5/16 Slotted Hex Head Worm Screw		7.5	0.26	100
HUBC10050	100 x 50	54	130	121	SS304 5/16 Slotted Hex Head Worm Screw		7.5	0.46	100
HUBC10080	100 x 75	54	130	121	SS304 5/16 Slotted Hex Head Worm Screw		7.5	0.51	100



# SS304 TYPE B HUBLESS RAPID COUPLING

COMPLY WITH CISPI 310-2012  
EN 877:2010

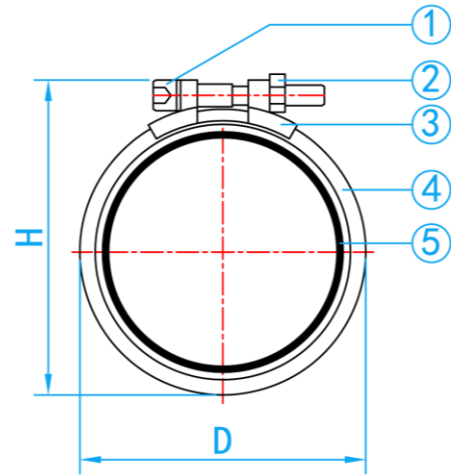
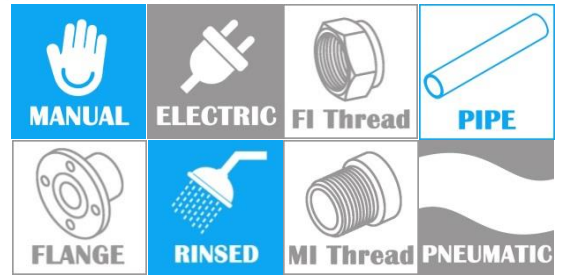

SIDE VIEW

INSTALLATION ASSEMBLY

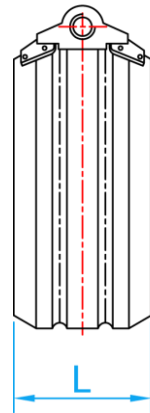

FRONT VIEW

## COMPONENT PARTS

ITEM	PARTS	MATERIAL
1.	Hexagon Socket head Screw	Galvanized Iron
2.	Wing Nut	Galvanized Iron
3.	Locking Component	Stainless Steel 304
4.	Band Clamp	Stainless Steel 304
5.	Rubber Gasket	NR

## STANDARD SPECIFICATIONS

SKU	SIZE (mm)	L (mm)	H (mm)	D (mm)	BOLT	BAR	INSTALL TORQUE (Nm)	WEIGHT (kg)
HUBC050B	50	41 ± 1	83.5	70.9	M8	0.5	11	0.1
HUBC080B	80	45 ± 1	108.0	98.9	M8		11	0.12
HUBC100B	100	45 ± 1	133.5	125.0	M8		15	0.21
HUBC125B	125	54 ± 1	158.2	150.0	M8		15	0.36
HUBC150B	150	54 ± 1	186.7	175.8	M8		15	0.38
HUBC200B	200	67 ± 1	244.0	227.0	M10		Until both locks come together	0.53



# STAINLESS STEEL 304 TYPE F HUBLESS HIGH RISE CLIPS

COMPLY WITH CISPI 301-2012



SKU: HUBC050F~HUBC080F



SKU: HUBC100F~HUBC150F



INSTALLATION ASSEMBLY

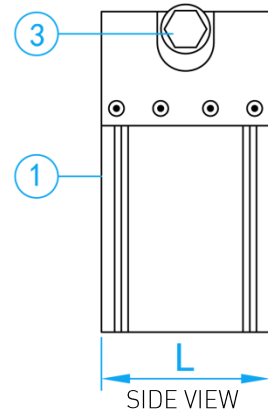

SIDE VIEW

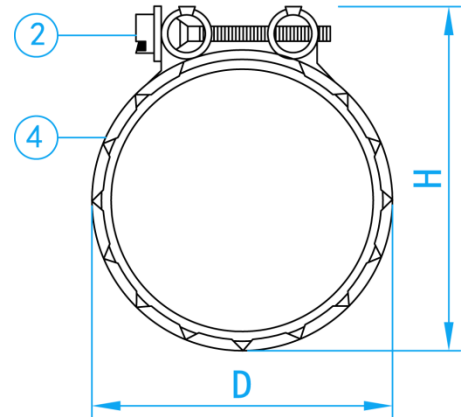

TOP VIEW

## COMPONENT PARTS

ITEM	PARTS	MATERIAL
1.	Metal collar	Stainless steel 304
2.	Locking parts	Galvanized iron
3.	Slotted hex washer head bolt	Galvanized iron
4.	Gasket	NR

## STANDARD SPECIFICATIONS

SKU	SIZE (mm)	H (mm)	D (mm)	L (mm)	BOLT	BAR	INSTALL TORQUE (Nm)	WEIGHT (kg)
HUBC050F	50	85.4	69.8	50±1	GI M8 Slotted Hex Washer Head Bolt	0.5	7.5	0.20
HUBC080F	80	109.7	94.4	54±1	GI M8 Slotted Hex Washer Head Bolt		7.5	0.25
HUBC100F	100	140	118.3	54±1	GI M8 Slotted Hex Washer Head Bolt		7.5	0.30
HUBC150F	150	190.4	174	77±1	GI M8 Slotted Hex Washer Head Bolt		7.5	0.56

# CV GRIP COLLAR



HUBCV50~80



HUBCV100~150



HUBCV200



INSTALLATION ASSEMBLY

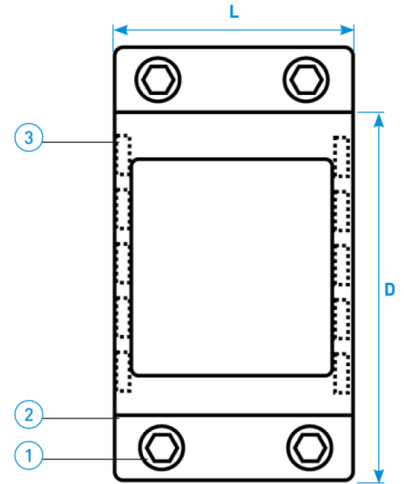

SIDE VIEW

### COMPONENT PARTS

ITEM	PARTS	MATERIAL
1	Hexagon Head Screw	Q195 Carbon Steel
2	Metal Collar	Q195 Carbon Steel
3	Claw Insert	Q195 Carbon Steel

### STANDARD SPECIFICATIONS

SKU	SIZE (mm)	L (mm)	D (mm)	BOLT	BAR	TORQUE (Nm)
HUBCV050*	50	69	73	M8	3	10~12
HUBCV080*	80	71	94	M8	3	10~12
HUBCV100	100	87	126	M10	3	18~20
HUBCV150	150	98	179	M10	3	18~20
HUBCV200*	200	111	229	M12	3	25~30

\* Availability upon request

# RAPID CLAMP KOMBI GRIP COLLAR

COMPLY WITH EN877:2010

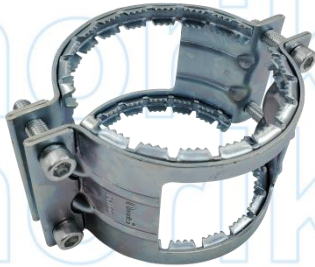
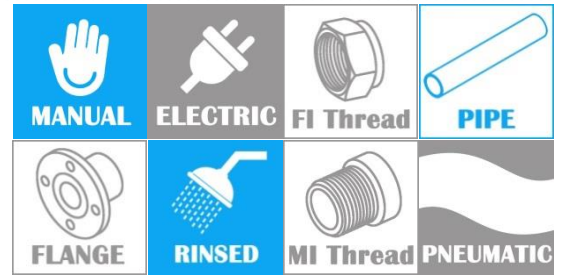

HUBKV050~150

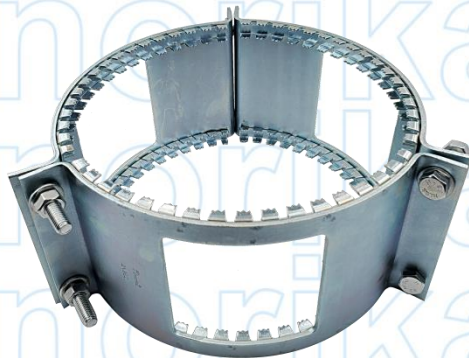

HUBKV200~300



INSTALLATION ASSEMBLY

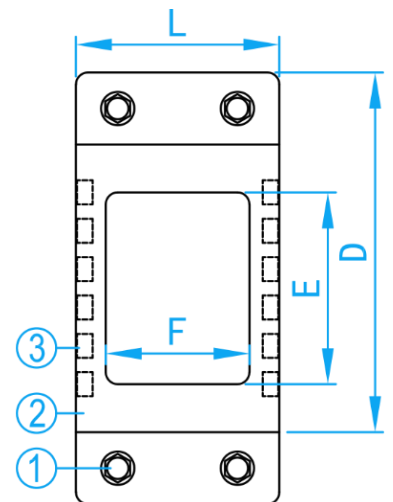

SIDE VIEW

## COMPONENT PARTS

ITEM	PARTS	MATERIAL
1	Hexagon Socket Head Screw	Special Steel C/W Galvanized
2	Metal Collar	Special Steel C/W Galvanized
3	Claw Insert	Special Steel C/W Galvanized

## DIMENSIONS

SKU	SIZE (mm)	L (mm)	D (mm)	E×F (mm)	BAR	BOLT	TORQUE (Nm)	WEIGHT (kg)
HUBKV050	50	88	106	60×60	7	M8	23-25	0.650
HUBKV080	80	88	130	64×60	5	M8	25-28	0.765
HUBKV100	100	88	160	84×60	5	M10	25-30	1.100
HUBKV125	125	118	210	84×60	5	M10	40-60	-
HUBKV150	150	118	230	84×80	5	M10	40-60	1.550
HUBKV200	200	146	287	130×110	2.5	M12	50-65	2.605
HUBKV250	250	146	320	140×110	2	M12	50-65	4.620
HUBKV300	300	185	419	150×145	1	M12	50-65	-

\* Used axially, extension resistance with hubless stainless steel clips (Type A, Type B & Type F).

# AISI304 RAPID CLAMP KOMBI GRIP COLLAR

COMPLY WITH EN877:2010

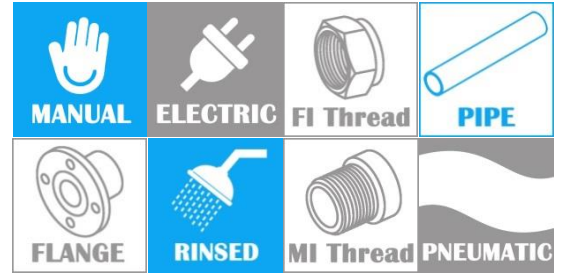

HUBKV050~150SS304

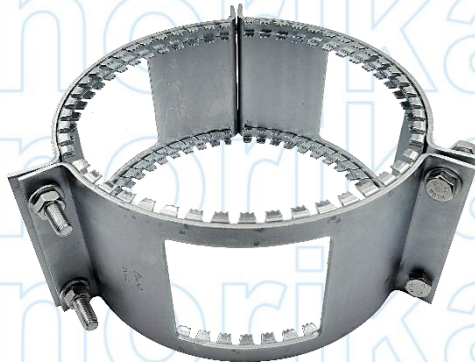

HUBKV200~300SS304



INSTALLATION ASSEMBLY

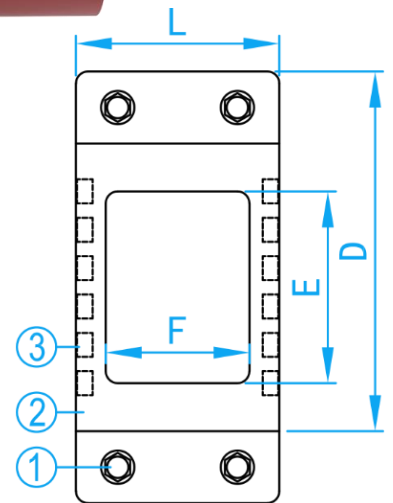

SIDE VIEW

## COMPONENT PARTS

ITEM	PARTS	MATERIAL
1	Hexagon Socket Head Screw	AISI304
2	Metal Collar	AISI304
3	Claw Insert	AISI304

## DIMENSIONS

SKU	SIZE (mm)	L (mm)	D (mm)	E×F (mm)	BAR	BOLT	TORQUE (Nm)	WEIGHT (kg)
HUBKV050SS304	50	88	106	60×60	7	M8	23~25	0.650
HUBKV080SS304	80	88	130	64×60	5	M8	25~28	0.765
HUBKV100SS304	100	88	160	84×60	5	M10	25~30	1.100
HUBKV125SS304	125	118	210	84×60	5	M10	40~60	-
HUBKV150SS304	150	118	230	84×80	5	M10	40~60	1.550
HUBKV200SS304	200	146	287	130×110	2.5	M12	50~65	2.605
HUBKV250SS304	250	146	320	140×110	2	M12	50~65	4.620
HUBKV300SS304	300	185	419	150×145	1	M12	50~65	-

\* Used axially. extension resistance with hubless stainless steel clips [Type A, Type B & Type F].