

## NORIKA PEX F6 MULTILAYER PIPES AND FITTINGS



Scan for  
installation video:



# SINGAPORE GREEN BUILDING PRODUCT (SGBP) CERTIFICATE



AWARDED TO

**Liang Chew Hardware Pte Ltd**

133 Kitchener Road Singapore 208517

FOR THE PRODUCT

**Norika**

CATEGORY: **Pipe & Fittings - Potable Water**

MANUFACTURED IN: **China**

PRODUCT MODEL(S)

**Refer to Appendix**



This product has been evaluated according to the certification requirements of the Singapore Green Building Product Certification Scheme. It has been awarded the rating:

**GOOD, 1 TICK**

**CEO**  
SGBC PTE LTD  
200 BRADDELL RD, BLOCK H, #02-04  
BCA BRADDELL CAMPUS, SINGAPORE 579700

CERTIFICATE NO.

**SGBP 4219**

ISSUE DATE

**10 February 2026**

REVISED ON

-

VALID THROUGH

**09 February 2028**

The use and reliance on this certificate is subject to the terms and conditions of the Singapore Green Building Product Certification Scheme. Revised certificates may also be issued at the discretion of SGBC Pte Ltd. The certification status may be verified on the SGBC Product Directory ([web.sgbc.online/public/product](http://web.sgbc.online/public/product)).



GOOD



VERY GOOD



EXCELLENT



LEADER

# SINGAPORE GREEN BUILDING PRODUCT (SGBP) CERTIFICATE



APPENDIX TO SGBP 4219 ,PAGE 1 OF 1

ISSUE DATE  
10 February 2026

VALID THROUGH  
09 February 2028

REVISED ON  
-

## PRODUCT MODEL(S)

[PIPES] - PIPPEX: [16mm, 20mm, 25mm, 32mm, 40mm, 50mm, 63mm and 75mm], [Fittings, Push-Fit] - (16mm, 20mm, 25mm and 32mm)(PEXF6EC || PEXF6E90 || PEXF6ES || PEXF6ET || PEXF6FIA || PEXF6MIA || PEXF6FIE || PEXF6MIE || PEXF6FIT || PEXF6MIT || PEXF6RT) // (20mm, 25mm and 32mm) (PEXF6RS || PEXF6RE90) // (16mm, 20mm, and 25mm) (PEXF6BV || PEXF6FE-Wallplate) // (16mm, 20mm)(PEXF6FE-Double Flange Elbow), [Fittings, Press-Fit] - (16mm, 20mm, 25mm, 32mm, 40mm, 50mm, 63mm and 75mm) (PEXF5E45 || PEXF5E90 || PEXF5ES || PEXF5RS || PEXF5FIA || PEXF5MIA || PEXF5ET || PEXF5RT || PEXF5FIT || PEXF5EC ) // (16mm, 20mm, 25mm, 32mm, 40mm, 50mm & 63mm) ( PEXF5RE90 || PEXF5FIE || PEXF5MIE ) // (16mm, 20mm, 25mm, 32mm, 40mm and 50mm) (PEXF5MIT || PEXF5FJC) // (16mm, 20mm and 25mm) (PEXF5FE-Wallplate Elbow) // (16mm and 20mm) (PEXF5FE-Assembly Double Elbow)

The use and reliance on this certificate is subject to the terms and conditions of the Singapore Green Building Product Certification Scheme. Revised certificates may also be issued at the discretion of SGBC Pte Ltd. The certification status may be verified on the SGBC Product Directory ([web.sgbc.online/public/product](http://web.sgbc.online/public/product)).



GOOD



VERY GOOD



EXCELLENT



LEADER

The **Norika® Multilayer PEX pipes**, is a three layer pipe in which it consist of materials PEX-B for its outside and inside layer while the middle layer is made of aluminum. The **Norika® Multilayer PEX pipes** have an operating pressure of 10bar and working temperature of 0°C to 70°C. External and internal layer is made of silane cross-linked polyethylene that is extensively used in distribution of potable water. The silane cross-linking provides superior chemical and mechanical properties. While the intermediate layer is an aluminum alloy with overlapped welding that guarantees a total barrier to the passage of oxygen and light and provides excellent mechanical and chemical properties. It is applicable for hot and cold potable water applications also used for under floor heating system. The **Norika® Multilayer PEX pipes** complies with **BS EN ISO 21003**, ensuring quality, safety, and performance in multilayer piping systems.

#### Main advantages of multilayer pipes:

- Increase in internal pressure resistance.
- Ductility. Thanks to its aluminum layer, once pipes have been curved it will keep that form.
- Tightness to oxygen diffusion.
- Dimensional stability.
- Long service life.
- Higher flow.

#### PAP: Polyethylene-Aluminum composite pipeline

A pipe composed of a welded aluminum tube as the middle layer, with both the inner and outer layers made of polyethylene plastic, bonded together using a special hot-melt adhesive through an extrusion molding process.

#### Why Crosslinking?

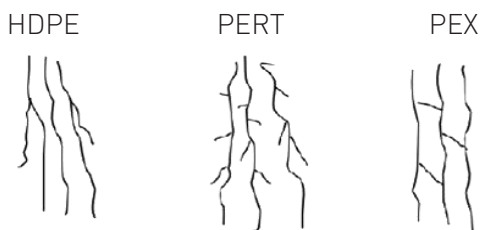

Changing the structure to increase heat resistance and strength of the pipe.

- Insoluble & infusible – solvent resistance, high-temperature resistance
- Crosslinked construction – Impact / tensile strength, creep resistance, scratch resistance

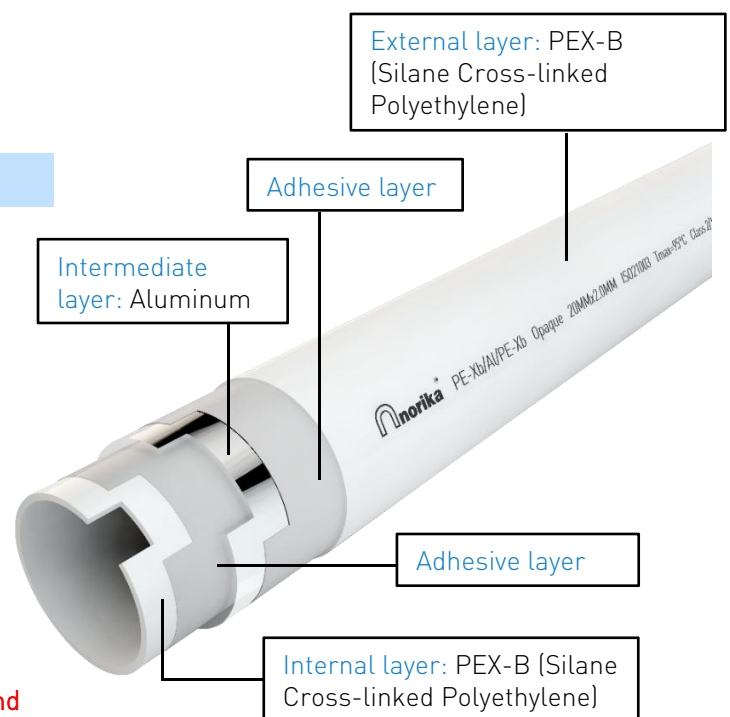

Raw Material	Application			
	Underfloor heating	Plumbing	Cooling & heating systems	Others
HDPE-AL-HDPE (HDPE: High density polyethylene)		✓		Pressure piping system, anti-corrosion engineering, special industrial components
PERT-AL-PERT (PERT: Heat resistant reinforced polyethylene)	✓	✓	✓	High performance fluid transport system
PEX-AL-PEX (Norika®) (PEX: Cross-linked polyethylene)	✓	✓	✓	

### Comparison Of The Three Cross-Linking Methods

Production Process	PEX-A (Peroxide Cross-linked polyethylene)		PEX-B (Silane Cross-linked polyethylene)		PEX-C (Radiation Cross-linked polyethylene)		
	Engel (Peroxide plunger method)	Daoplas (Infrared cross-linking method)	Monsil (One-step method)	Sioplas (Two-step method)	γ-co	β-accelerator	UV
Basic formulation of Materials	HDPE + Peroxide + Antioxidants		HDPE + Peroxide + Antioxidants + Silane + Catalyst		HDPE + Antioxidants + Photosensitizer		
Agglomerate Structure	Planar Crosslinking		Volume Crosslinking		Volume Crosslinking		
Reaction by-Products	Initiator by-products (can be removed by post-treatment)		Initiator by-products + silane oligomers + silane hydrolysis by-products <sup>Ⓢ</sup> (Silane is difficult to remove)		Photosensitizer byproduct (Generally does not require post-processing)		
Rigidity	Poor		Good		Average		
Flexibility	Good		Poor		Average		
Hygiene Performance	Average		Poor		Good		
Aging Resistance	Poor		Average		Poor		
Memorability	Excellent memory effect, especially for use with cold expansion connections		Minimal shape memory, not suitable for cold expansion fittings		Minimal shape memory, not suitable for cold expansion fittings		
Cracking & Repair	Heat the kinked area with a heat gun until the material becomes translucent, then allow to cool.		The pipe is bent into a kink will produce white cracks, for the dead bend of the pipe, can not be repaired		PEX-C can use a heat gun to heat to transparent for small kink recovery, the effect is not as perfect as PEX-A		
Cross-linking Degree	≥70%		≥65%		≥60%		

### Comparison Of Hydrostatic Stress

Test Conditions	Hydrostatic stress (MPa)	
	PE-RT	PE-X
20°C, 1h	9.9	12
95°C, 22h	3.8	4.7
95°C, 165h	3.6	4.6
95°C, 1000h	3.4	4.4

PEX-A, PEX-B, PERT+EVOH & Multilayer Technical Parameter Comparison Table

	PEX-A (Other Brand)	PEX (PEX-B)	EVOH+PERT pure plastic pipe (Other Brand)	NORIKA Multilayer (PEX multilayer pipe)	Note
Production Process	Engel (Peroxide plunger method)	Monsil (One-step method)	multilayer co- extrusion	Multilayer co-extrusion + metal welding + tube boiling crosslink	
Basic formulation of materials	HDPE + Peroxide + Antioxidants	HDPE + Peroxide + Antioxidants + Silane + Catalyst	PERT+EVOH	PEX-B Raw Material+Aluminium	
Agglomerate structure	Planar Crosslinking	volume Crosslinking	PERT+EVOH	PEXB-AL-PEXB	NORIKA multilayer pipe, based on the bulk crosslinking of PEXb, has a metal layer for reinforcement, achieving the most stable state.
Rigidity	LOW	AVERAGE	LOW	HIGH	
Flexibility	HIGH	HIGH	HIGH	AVERAGE Can be bent by hand	
Hygiene performance	AVERAGE	AVERAGE	GOOD	EXCELLENT	Due to the metal layer, NORIKA multilayer pipe can 100% barriers off light and oxygen
Aging resistance	LOW	AVERAGE	AVERAGE	HIGH	
Memorability	HIGH	LOW	LOW	LOW	
Cracking & Repair	AVERAGE Dead bend can be repaired	AVERAGE Slight bend can be repaired	LOW Crack cannot be repaired	EXCELLENT Crack cannot be repaired	The structure with multi-layer distribution of metal and non-metal significantly enhances crack resistance.
Cross-linking degree	≥70%	≥65%	No Crosslink	Same With NORIKA PEX-b	
Average coefficient of expansion(mm/mK)	HIGH (0.15)	HIGH (0.2)	NA	LOW (0.025) Hard to be deformed	The lower the value, the smaller the deformation impact caused by hot-cold alternation, and the less damage to the building.
roughness (mm)	AVERAGE (0.007)	LOW (0.0001)	NA	LOW (0.0007)	A low roughness can reduce water flow resistance and prevent sediment accumulation, further improving hygiene.
Max working temperature (Tmax, °C)	90	90	NA	95	The maximum temperature at which the pipe can work normally for a long term.
Short time extream high temperature (Tmal, °C)	100	100	NA	110	Extremely high temperature. Under this temperature, the pipe usually works for no more than 100 hours.
Working pressure (70°C, MPa)	1	1	NA	1	
Density (g/cm³)	NA	0.946	0.941	0.946 (Plastic Layer)	
Vicat Softening temperature (°C)	NA	133	125	133 (Plastic Layer)	It is generally understood as the critical temperature at which the pipe softens and deforms due to heat.
Yeild Streee (kg/cm²)	NA	210	210	210 (Plastic Layer)	
Elongation at Break (%)	NA	468	750	468 (Plastic Layer)	

## Norika® PEX Multilayer Extrapolated Strength Values

Prediction 20°C				Prediction 70°C			
Time [h]	Time [y]	$\sigma$ LPL [MPa]	$\sigma$ LTHS [MPa]	Time [h]	Time [y]	$\sigma$ LPL [MPa]	$\sigma$ LTHS [MPa]
1	0.00	22.99	23.15	1	0.00	15.61	15.78
10	0.00	21.44	21.59	10	0.00	14.03	14.18
22	0.00	20.94	21.08	22	0.00	13.53	13.67
100	0.01	20.00	20.14	100	0.01	12.61	12.74
165	0.02	19.70	19.83	165	0.02	12.32	12.44
1000	0.11	18.65	18.78	1000	0.11	11.32	11.44
4000	0.46	17.89	18.01	4000	0.46	10.62	10.80
8760	1.00	17.47	17.59	8760	1.00	10.24	10.34
438000	50.00	15.51	15.62	438000	50.00	8.53	8.62

Prediction 95°C				Prediction 110°C			
Time [h]	Time [y]	$\sigma$ LPL [MPa]	$\sigma$ LTHS [MPa]	Time [h]	Time [y]	$\sigma$ LPL [MPa]	$\sigma$ LTHS [MPa]
1	0.00	11.56	11.71	1	0.00	9.08	9.23
10	0.00	10.09	10.22	10	0.00	7.74	7.87
22	0.00	9.63	9.76	22	0.00	7.33	7.45
100	0.01	8.80	8.92	100	0.01	6.60	6.71
165	0.02	8.55	8.66	165	0.02	6.38	6.48
1000	0.11	7.68	7.78	1000	0.11	5.63	5.72
4000	0.46	7.08	7.17	4000	0.46	5.11	5.19
8760	1.00	6.75	6.84	8760	1.00	4.84	4.92

Temperature	Extrapolation time [h]	Extrapolation time [y]	Test temperature used	Extrapolation time factor, ke
20°C	876000	100.00	95°C	100.00
70°C	490707	56.02	110°C	50.00
95°C	39257	4.48	110°C	4.00
110°C	9814	1.12	110°C	1.00

# Pressure loss

Calculation formula: Colebrook - White Equation

$$r = f \times \frac{L}{D} \times P \times \frac{V^2}{2}$$

$$\frac{1}{\sqrt{f}} = -2 \log \left( \frac{e}{3.7D} + \frac{2.51}{Re\sqrt{f}} \right)$$

$$Re = \frac{\rho \times V \times D}{\mu}$$

## Description:

- $r$  = head loss (Pa)
- $f$  = friction factor
- $\rho$  = density of the fluid (kg/m<sup>3</sup>)
- $V$  = the velocity of the fluid (m/s)
- $D$  = the pipe inner diameter (m)
- $L$  = pipe length (m)
- $e$  = relative roughness
- $Re$  = Reynolds number
- $\mu$  = dynamic viscosity (Pa·s)



# TEST CERTIFICATE

## POTABLE WATER FITTINGS SCHEME

**Certificate Number** : TC-J0244  
**Issue No:** 04

This Certificate is awarded to the following product(s) which has / have complied with the requirements of the listed standard(s) in accordance with Stipulation of Standards and Requirements for Water Fittings for Use in Potable Water Service Installations.

**Client** : **Liang Chew Hardware Pte Ltd**  
 133 Kitchener Road  
 Singapore 208517

**Product** : Multilayer Pipes & Fittings (Push-fit)

**Brand / Model** : Norika / PIPPEX & PEXF6

**Detail** : Sizes (mm): 16, 20, 25 & 32

**Test Standard(s)** : BS EN ISO 21003-1: 2008, BS EN ISO 21003-2: 2008 + A1: 2011, BS EN ISO 21003-3: 2008, BS EN ISO 21003-5: 2008, AS/NZS 4020: 2005, AS/NZS 4020: 2018, SS 375: 2015, BS EN 12165: 2016

**Test Report(s)** : 2524187-OYC, 2120978/01-OYC, 2120978/02-OYC, 1820215/01-OYC, 2020852-CPC, 1820215/04-CPC, 2020843/01-CPC, 2020889-CPC, 21802731-CLC

**A sample of the product submitted was tested and found to comply with the test requirements of the above standard(s).**

**Date of Original Issue** : 10 March 2021

**Date of Last Revision** : 04 March 2025

**Date of Expiry** : 09 March 2027

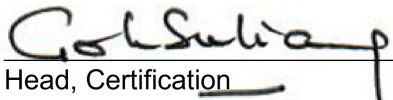
  
 Head, Certification  
 Singapore Test Lab Pte Ltd

This Certificate is part of a full report and should be read in conjunction with it. This Certificate remains the property of Singapore Test Lab Pte Ltd and shall be returned upon request. The use of this Certificate is subjected to the Terms and Conditions of Singapore Test Lab Pte Ltd. The manufacturer is solely responsible for the compliance of any product that has the same designation as the product type tested.



Singapore Test Lab Pte Ltd certifies according to ISO / IEC 17065



# PEX-B/AL/PEX-B THREE LAYER PIPE

COMPLY WITH BS EN ISO 21003-1:2008  
 BSEN ISO 21003-2:2008+A1:2011  
 AS/NZS 4020:2005  
 SS 375:2015

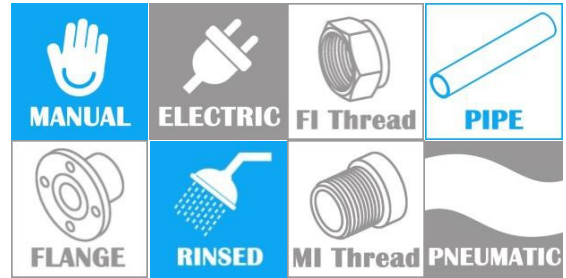

## MULTILAYER PIPES

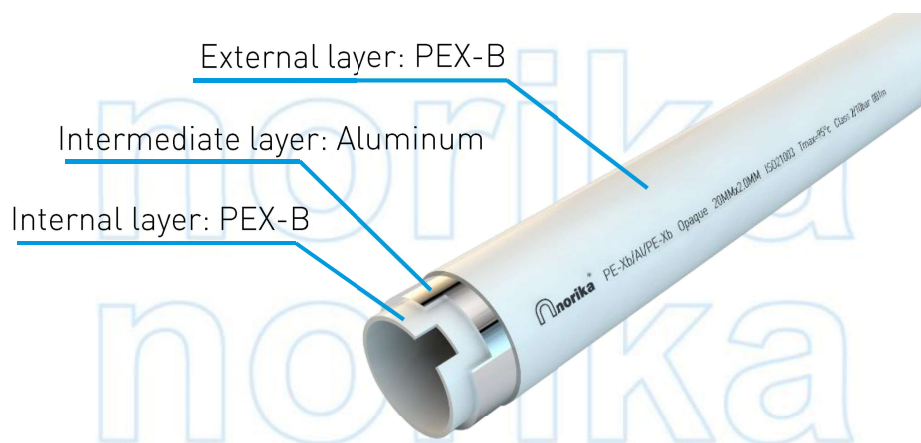

COMPONENTS	
Material Name	Advantages
PEX-B (Cross-linked Polyethylene)	Light weight, corrosion resistance, easy installation, and low cost.
Aluminum	Improves the compressive and impact resistance of pipes, ensuring their stability and effectively isolating them from oxygen penetration. This material is easy to cut, bendable, and non-rebounding.

### STANDARD SPECIFICATION

Working Pressure	10 Bar
Working Temperature	0 ~ 70°C
Applications	Hot and cold potable water system.
<b>**Attention During Installation</b>	<b>Exclusively indoor installation only.</b> (While there is some UV resistance, it may not be sufficient, so it's advisable to add a protective cover for enhanced protection.)

# PEX-B/AL/PEX-B THREE LAYER PIPE

COMPLY WITH BS EN ISO 21003-1:2008  
 BSEN ISO 21003-2:2008+A1:2011  
 AS/NZS 4020:2005  
 SS 375:2015

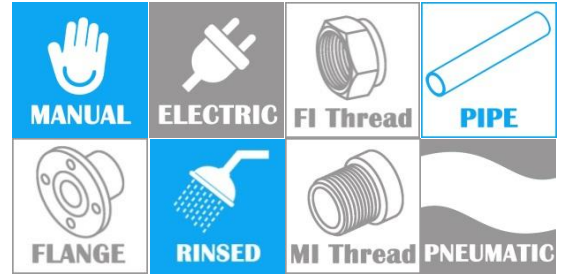

STRAIGHT TUBE  
 SKU: PIPPEXL016~075



COILING TUBE  
 SKU: PIPPEX016~032

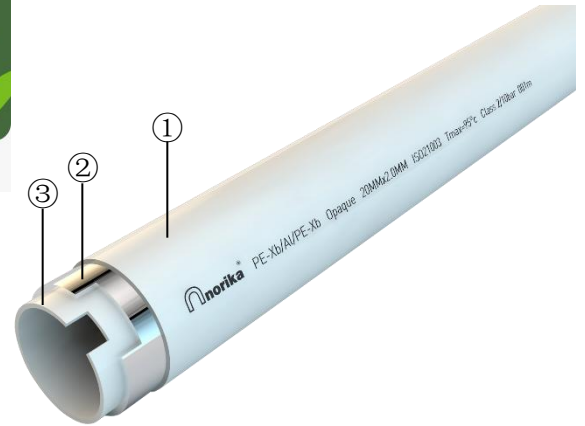

**\*\*Exclusively indoor installation only.**

STANDARD SPECIFICATION	
Working Pressure	10 Bar
Working Temperature	0 ~ 60°C
Applications	Hot and cold potable water system.

COMPONENT PARTS		
ITEM	PARTS	MATERIAL
1	Outside layer	PEX-B
2	Middle layer	Aluminum
3	Inside layer	PEX-B

## DIMENSIONS

SKU	Outside Diameter (mm)	Inside Diameter (mm)	Thickness (mm)	Tolerance Of Pipe Thickness (mm)	Length (mm)	WEIGHT (kg/m)
PIPPEXL016	16	12	2.0	2.00~2.25	5800	0.121
PIPPEXL020	20	16	2.0	2.00~2.25	5800	0.166
PIPPEXL025	25	20	2.5	2.40~2.70	5800	0.235
PIPPEXL032	32	26	3.0	2.90~3.20	5800	1.040
PIPPEXL040	40	32	4.0	4.00~4.60	5800	0.567
PIPPEXL050	50	41	4.5	4.50~5.20	5800	0.820
PIPPEXL063	63	51	6.0	6.00~6.80	5800	1.334
PIPPEXL075	75	60	7.5	7.50~8.50	5800	1.893

## DIMENSIONS

SKU	Outside Diameter (mm)	Inside Diameter (mm)	Thickness (mm)	Tolerance Of Pipe Thickness (mm)	WEIGHT (kg/m)	M/CTN
PIPPEX016	16	12	2.0	2.00~2.25	0.121	200M
PIPPEX020	20	16	2.0	2.00~2.25	0.166	200M
PIPPEX025	25	20	2.5	2.40~2.70	0.235	100M
PIPPEX032	32	26	3.0	2.90~3.20	1.040	50M

# PEX MULTI LAYER PIPES AND FITTINGS



COMPLY WITH BS EN ISO 21003-1:2008  
 BS EN ISO 21003-3:2008  
 BS EN ISO 21003-5:2008  
 BS EN 12165:2016  
 AS/NZS 4020:2005  
 SS 375:2015

## F6 PUSH-FIT COMPONENTS:

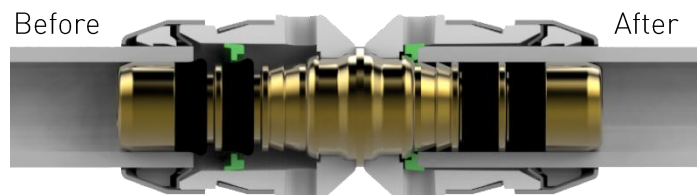
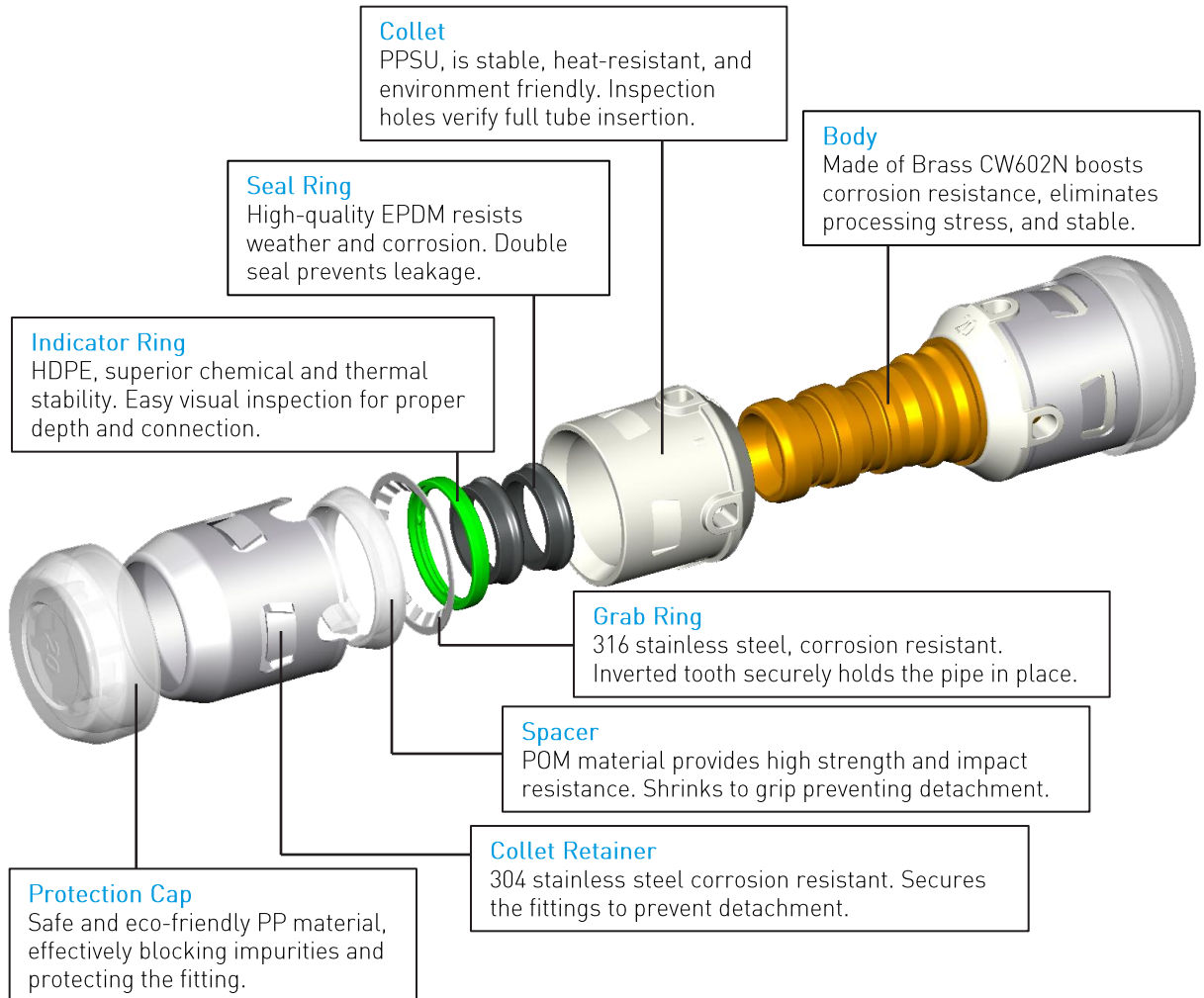

### STANDARD SPECIFICATION

Working Pressure	10 Bar
Working Temperature	0 ~ 70°C
Applications	Hot and cold potable water system, Underfloor heating system

# INSTALLATION GUIDE:

## 1. Pipe cutting

Cut the pipe vertically and precisely with a sharp pipe cutter.

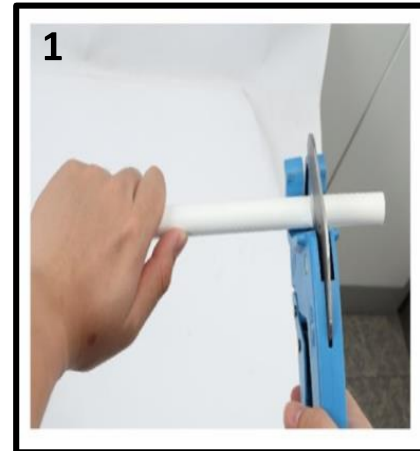

## 2. Rounding and beveling

- **Multilayer pipe:**

Round and bevel the end holes with reamer.

- **Pex pipe:**

Round the end holes with reamer, no need to bevel.

If you want to insert quickly and easily, you can bevel the pipe.

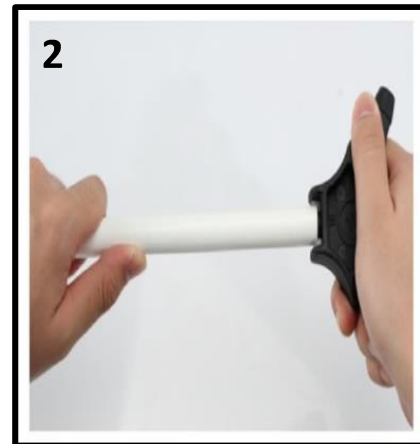

## 3. Removing

Removing the protective cap from the fitting. Make sure that both the fitting and pipe are clean and free of dirt and debris before making a connection.

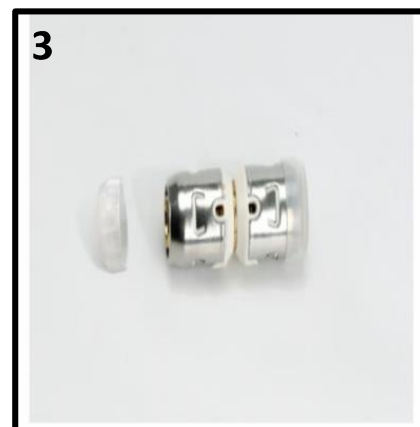

# INSTALLATION GUIDE:

## 4. Inserting

Choose the right size push-fitting for the pipe, push the pipe into the fitting firmly. Note that the pipe should be inserted in parallel until the green indicator ring is seen. Doesn't require any tools for inserting.

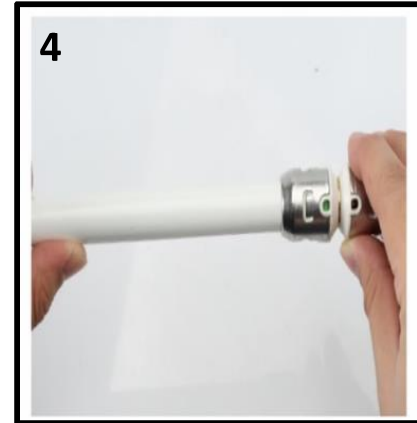

## 5. Checking

Checking the installed fitting, it is indicating that the fitting is properly installed if the green indicator ring can be seen through the inspection holes. The pipeline can only be installed after hydrostatic test.

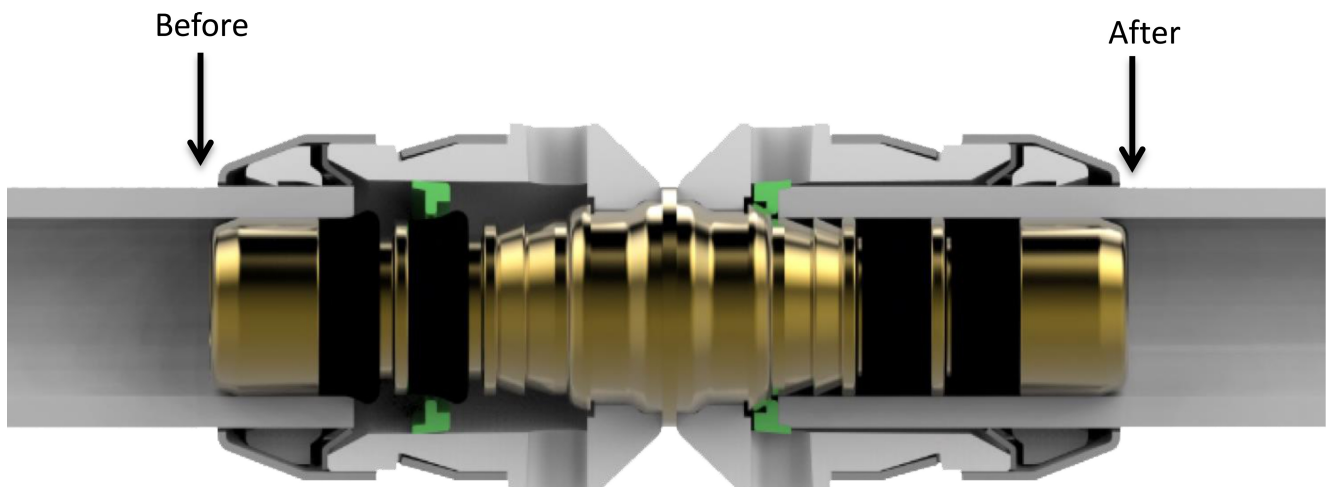
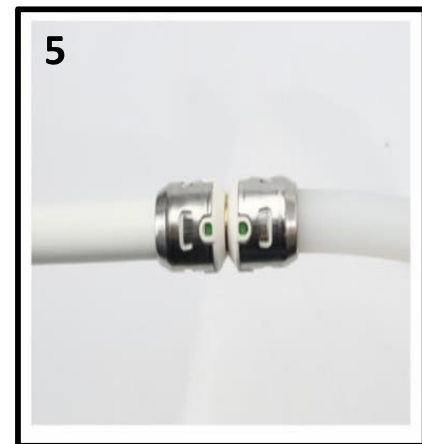

# PEX MULTI LAYER PIPES AND FITTINGS



COMPLY WITH BS EN ISO 21003-1:2008  
 BS EN ISO 21003-3:2008  
 BS EN ISO 21003-5:2008  
 BS EN 12165:2016  
 AS/NZS 4020:2005  
 SS 375:2015



## F6 PUSH-FIT PEX EQUAL SOCKET

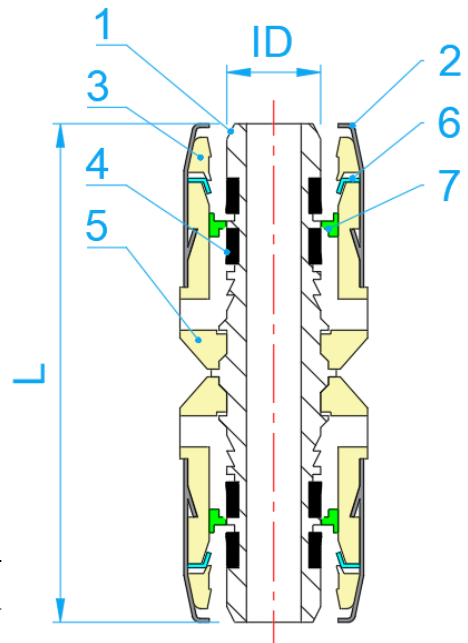

SECTION VIEW

### COMPONENT PARTS

ITEM	PARTS	MATERIAL
1	Body	DZR Brass
2	Collet Retainer	AISI304
3	Spacer	POM
4	Seal Ring	EPDM
5	Collet	PPSU (Polyphenylene Sulfone Resin)
6	Grab Ring	AISI316
7	Indicator Ring	HDPE (High Density Polyethylene)

### DIMENSIONS

SKU	SIZE (mm)	ID (mm)	L (mm)	WEIGHT (kg)	PCS/CTN
PEXF6ES016	16	11.80	64.0	0.066	144
PEXF6ES020	20	15.80	67.0	0.096	120
PEXF6ES025	25	19.75	77.5	0.150	96
PEXF6ES032	32	25.75	88.5	0.249	48

# PEX MULTI LAYER PIPES AND FITTINGS



COMPLY WITH BS EN ISO 21003-1:2008  
 BS EN ISO 21003-3:2008  
 BS EN ISO 21003-5:2008  
 BS EN 12165:2016  
 AS/NZS 4020:2005  
 SS 375:2015



## F6 PUSH-FIT PEX REDUCING SOCKET

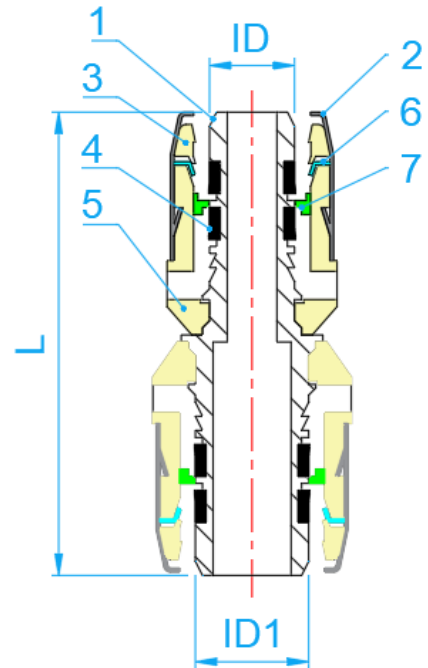

SECTION VIEW

### COMPONENT PARTS

ITEM	PARTS	MATERIAL
1	Body	DZR Brass
2	Collet Retainer	AISI304
3	Spacer	POM
4	Seal Ring	EPDM
5	Collet	PPSU (Polyphenylene Sulfone Resin)
6	Grab Ring	AISI316
7	Indicator Ring	HDPE (High Density Polyethylene)

### DIMENSIONS

SKU	SIZE (mm)	ID (mm)	ID1 (mm)	L (mm)	WEIGHT (kg)	PCS/CTN
PEXF6RS02016	20X16	11.80	15.80	65.5	0.082	160
PEXF6RS02516	25X16	11.80	19.75	71.0	0.111	120
PEXF6RS02520	25X20	15.80	19.75	72.5	0.124	120
PEXF6RS03216	32X16	11.80	25.75	76.5	0.168	72
PEXF6RS03220	32X20	15.80	25.75	78.0	0.182	80
PEXF6RS03225	32X25	19.75	25.75	83.0	0.204	60

# PEX MULTI LAYER PIPES AND FITTINGS



COMPLY WITH BS EN ISO 21003-1:2008  
 BS EN ISO 21003-3:2008  
 BS EN ISO 21003-5:2008  
 BS EN 12165:2016  
 AS/NZS 4020:2005  
 SS 375:2015



## F6 PUSH-FIT PEX FEMALE ADAPTOR

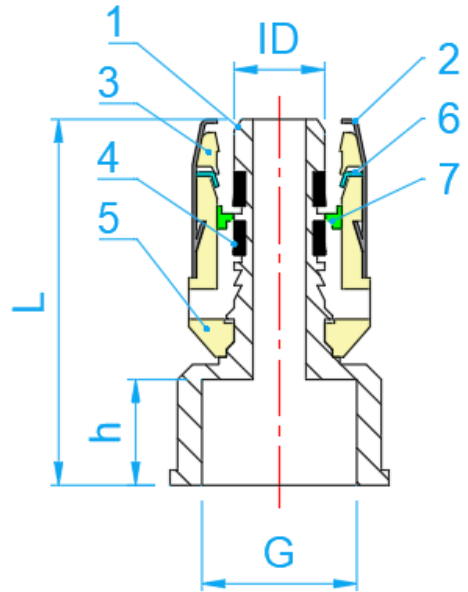

SECTION VIEW

### COMPONENT PARTS

ITEM	PARTS	MATERIAL
1	Body	DZR Brass
2	Collet Retainer	AISI304
3	Spacer	POM
4	Seal Ring	EPDM
5	Collet	PPSU (Polyphenylene Sulfone Resin)
6	Grab Ring	AISI316
7	Indicator Ring	HDPE (High Density Polyethylene)

### DIMENSIONS

SKU	SIZE (mmxinch)	ID (mm)	G BSP (inch)	h (mm)	L (mm)	WEIGHT (kg)	PCS/CTN
PEXF6FIA01616	16×1/2"	11.80	1/2"	15	48.5	0.068	144
PEXF6FIA01620	16×3/4"	11.80	3/4"	16	49.5	0.085	96
PEXF6FIA02016	20×1/2"	15.80	1/2"	15	50.0	0.081	96
PEXF6FIA02020	20×3/4"	15.80	3/4"	16	51.0	0.097	96
PEXF6FIA02516	25×1/2"	19.75	1/2"	15	55.0	0.103	80
PEXF6FIA02520	25×3/4"	19.75	3/4"	16	56.0	0.119	80
PEXF6FIA02525	25×1"	19.75	1"	18	57.5	0.156	64
PEXF6FIA03220	32×3/4"	25.75	3/4"	16	66.0	0.174	80
PEXF6FIA03225	32×1"	25.75	1"	18	63.0	0.199	80
PEXF6FIA03232	32×1 1/4"	25.75	1 1/4"	19	65.5	0.234	64

# PEX MULTI LAYER PIPES AND FITTINGS



COMPLY WITH BS EN ISO 21003-1:2008  
 BS EN ISO 21003-3:2008  
 BS EN ISO 21003-5:2008  
 BS EN 12165:2016  
 AS/NZS 4020:2005  
 SS 375:2015



## F6 PUSH-FIT PEX MALE ADAPTOR

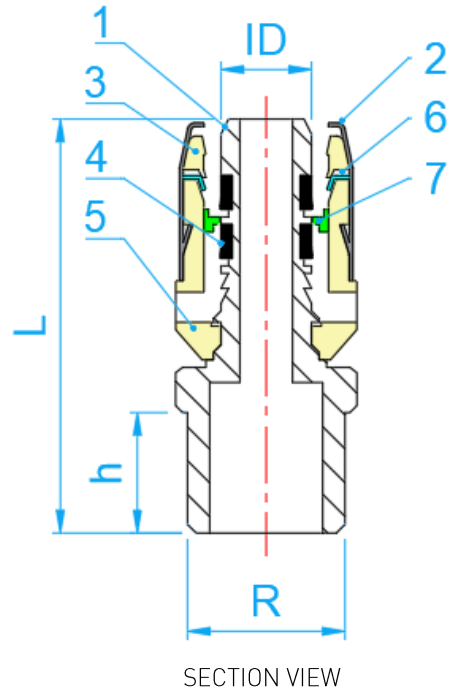

### COMPONENT PARTS+

ITEM	PARTS	MATERIAL
1	Body	DZR Brass
2	Collet Retainer	AISI304
3	Spacer	POM
4	Seal Ring	EPDM
5	Collet	PPSU (Polyphenylene Sulfone Resin)
6	Grab Ring	AISI316
7	Indicator Ring	HDPE (High Density Polyethylene)

### DIMENSIONS

SKU	SIZE (mmxinch)	ID (mm)	R BSPT (inch)	h (mm)	L (mm)	WEIGHT (kg)	PCS/CTN
PEXF6MIA01616	16X1/2"	11.80	1/2"	14	55.0	0.069	144
PEXF6MIA01620	16X3/4"	11.80	3/4"	15	52.0	0.077	144
PEXF6MIA02016	20X1/2"	15.80	1/2"	14	57.0	0.086	144
PEXF6MIA02020	20X3/4"	15.80	3/4"	15	58.0	0.095	120
PEXF6MIA02516	25X1/2"	19.75	1/2"	14	66.0	0.130	80
PEXF6MIA02520	25X3/4"	19.75	3/4"	15	67.0	0.140	64
PEXF6MIA02525	25X1"	19.75	1"	16	60.0	0.141	64
PEXF6MIA03216	32X1/2"	25.75	1/2"	14	71.5	0.173	80
PEXF6MIA03220	32X3/4"	25.75	3/4"	15	72.5	0.180	80
PEXF6MIA03225	32X1"	25.75	1"	16	73.5	0.204	80
PEXF6MIA03232	32X1 1/4"	25.75	1 1/4"	19	70.0	0.240	72

# PEX MULTI LAYER PIPES AND FITTINGS



COMPLY WITH BS EN ISO 21003-1:2008  
 BS EN ISO 21003-3:2008  
 BS EN ISO 21003-5:2008  
 BS EN 12165:2016  
 AS/NZS 4020:2005  
 SS 375:2015



## F6 PUSH-FIT PEX END CAP

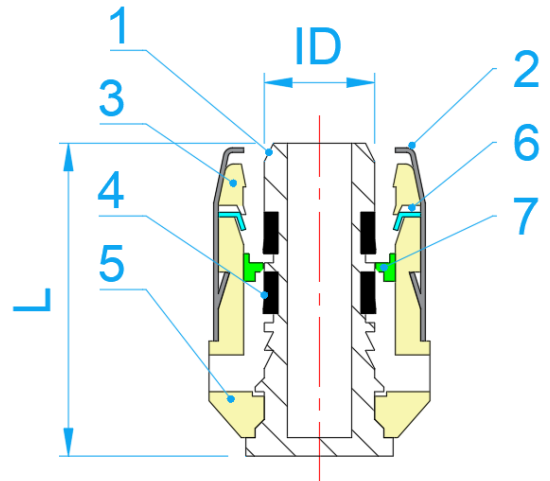

SECTION VIEW

### COMPONENT PARTS

ITEM	PARTS	MATERIAL
1	Body	DZR Brass
2	Collet Retainer	AISI304
3	Spacer	POM
4	Seal Ring	EPDM
5	Collet	PPSU (Polyphenylene Sulfone Resin)
6	Grab Ring	AISI316
7	Indicator Ring	HDPE (High Density Polyethylene)

### DIMENSIONS

SKU	SIZE (mm)	ID (mm)	L (mm)	WEIGHT (kg)	PCS/CTN
PEXF6EC016	16	11.80	34.0	0.037	288
PEXF6EC020	20	15.80	35.5	0.054	192
PEXF6EC025	25	19.75	40.5	0.086	128
PEXF6EC032	32	25.75	46.0	0.142	108

# PEX MULTI LAYER PIPES AND FITTINGS



COMPLY WITH BS EN ISO 21003-1:2008  
 BS EN ISO 21003-3:2008  
 BS EN ISO 21003-5:2008  
 BS EN 12165:2016  
 AS/NZS 4020:2005  
 SS 375:2015



## F6 PUSH-FIT PEX REDUCING ELBOW

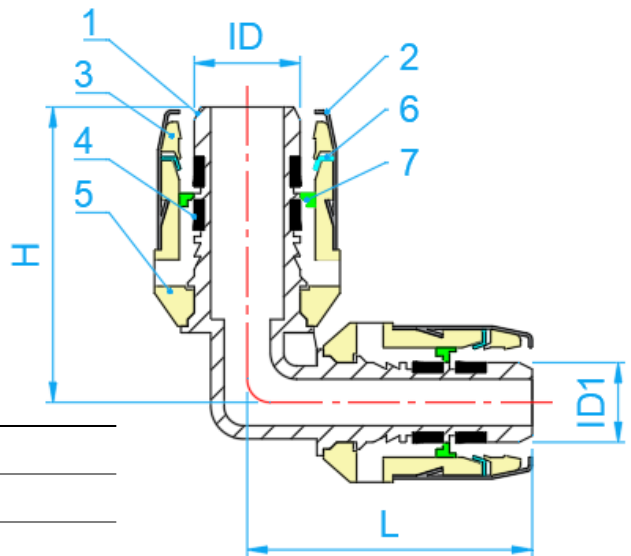

SECTION VIEW

### COMPONENT PARTS

ITEM	PARTS	MATERIAL
1	Body	DZR Brass
2	Collet Retainer	AISI304
3	Spacer	POM
4	Seal Ring	EPDM
5	Collet	PPSU (Polyphenylene Sulfone Resin)
6	Grab Ring	AISI316
7	Indicator Ring	HDPE (High Density Polyethylene)

### DIMENSIONS

SKU	SIZE (mm)	ID (mm)	ID1 (mm)	L (mm)	H (mm)	WEIGHT (kg)	PCS/CTN
PEXF6RE9002016	20X16	15.80	11.80	45	47	0.126	128
PEXF6RE9002516	25X16	19.75	11.80	47	53	0.111	100
PEXF6RE9002520	25X20	19.75	15.80	49	53	0.155	84
PEXF6RE9003216	32X16	25.75	11.80	50	60	0.199	72
PEXF6RE9003220 *	32X20	25.75	15.80	53	60	-	-
PEXF6RE9003225 *	32X25	25.75	19.75	59	60	-	-

\*This item requires special ordering. Please consult with a salesperson for the estimated lead time.

# PEX MULTI LAYER PIPES AND FITTINGS



COMPLY WITH BS EN ISO 21003-1:2008  
 BS EN ISO 21003-3:2008  
 BS EN ISO 21003-5:2008  
 BS EN 12165:2016  
 AS/NZS 4020:2005  
 SS 375:2015



## F6 PUSH-FIT PEX EQUAL ELBOW

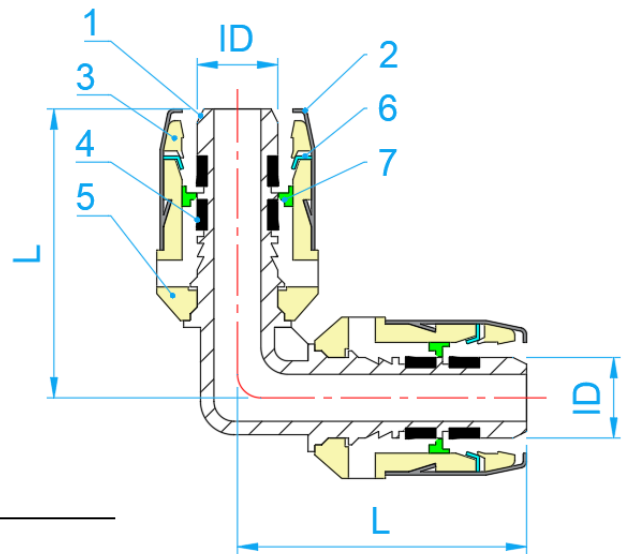

SECTION VIEW

### COMPONENT PARTS

ITEM	PARTS	MATERIAL
1	Body	DZR Brass
2	Collet Retainer	AISI304
3	Spacer	POM
4	Seal Ring	EPDM
5	Collet	PPSU (Polyphenylene Sulfone Resin)
6	Grab Ring	AISI316
7	Indicator Ring	HDPE (High Density Polyethylene)

### DIMENSIONS

SKU	SIZE (mm)	ID (mm)	L (mm)	WEIGHT (kg)	PCS/CTN
PEXF6E90016	16	11.80	43	0.079	96
PEXF6E90020	20	15.80	47	0.120	112
PEXF6E90025	25	19.75	53	0.150	80
PEXF6E90032	32	25.75	63	0.312	42

# PEX MULTI LAYER PIPES AND FITTINGS



COMPLY WITH BS EN ISO 21003-1:2008  
 BS EN ISO 21003-3:2008  
 BS EN ISO 21003-5:2008  
 BS EN 12165:2016  
 AS/NZS 4020:2005  
 SS 375:2015



## F6 PUSH-FIT PEX 45° ELBOW

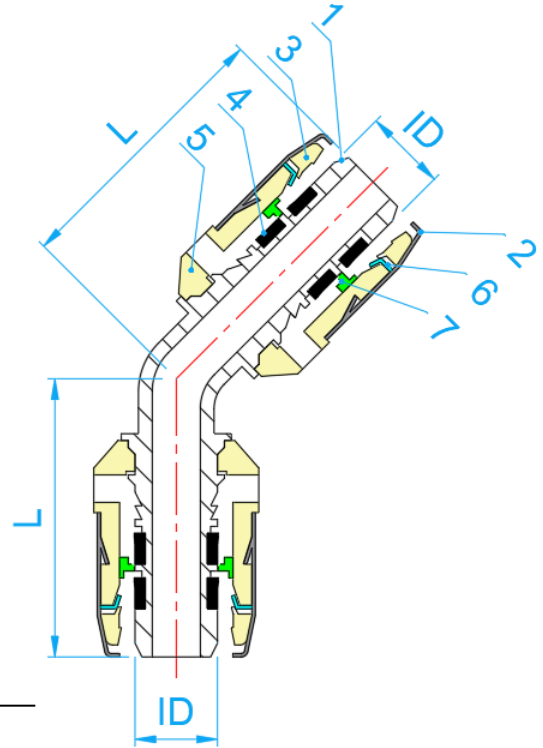

SECTION VIEW

### COMPONENT PARTS

ITEM	PARTS	MATERIAL
1	Body	DZR Brass
2	Collet Retainer	AISI304
3	Spacer	POM
4	Seal Ring	EPDM
5	Collet	PPSU (Polyphenylene Sulfone Resin)
6	Grab Ring	AISI316
7	Indicator Ring	HDPE (High Density Polyethylene)

### DIMENSIONS

SKU	SIZE (mm)	ID (mm)	L (mm)	WEIGHT (kg)	PCS/CTN
PEXF6E45016	16	11.80	40.5	0.078	96

# PEX MULTI LAYER PIPES AND FITTINGS



COMPLY WITH BS EN ISO 21003-1:2008  
 BS EN ISO 21003-3:2008  
 BS EN ISO 21003-5:2008  
 BS EN 12165:2016  
 AS/NZS 4020:2005  
 SS 375:2015



## F6 PUSH-FIT PEX FI ELBOW

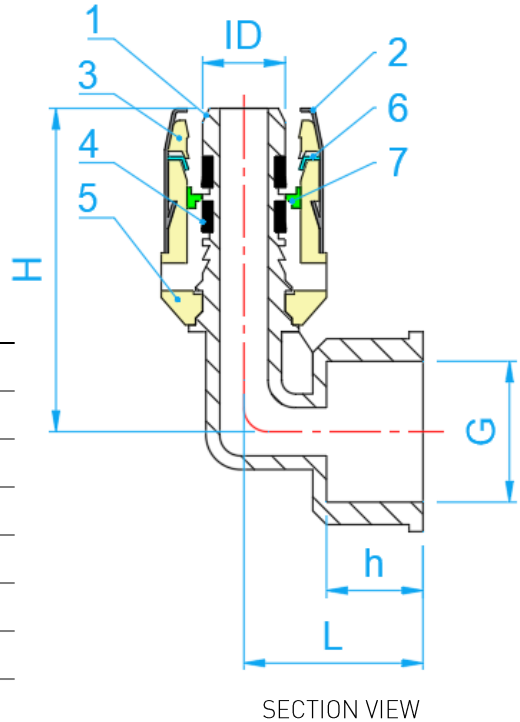

### COMPONENT PARTS

ITEM	PARTS	MATERIAL
1	Body	DZR Brass
2	Collet Retainer	AISI304
3	Spacer	POM
4	Seal Ring	EPDM
5	Collet	PPSU (Polyphenylene Sulfone Resin)
6	Grab Ring	AISI316
7	Indicator Ring	HDPE (High Density Polyethylene)

### DIMENSIONS

SKU	SIZE (mmxinch)	ID (mm)	G BSP (inch)	h (mm)	L (mm)	H (mm)	WEIGHT (kg)	PCS/CTN
PEXF6FIE01616	16X1/2"	11.80	1/2"	15	26	47	0.082	96
PEXF6FIE01620	16X3/4"	11.80	3/4"	16	27	50	0.099	112
PEXF6FIE02016	20X1/2"	15.80	1/2"	15	27	49	0.102	80
PEXF6FIE02020	20X3/4"	15.80	3/4"	16	28	51	0.112	80
PEXF6FIE02520	25X3/4"	19.75	3/4"	16	30	56	0.160	72
PEXF6FIE02525	25X1"	19.75	1"	18	32	60	0.195	72
PEXF6FIE03220 *	32X3/4"	25.75	3/4"	16	33	62	-	-
PEXF6FIE03225	32X1"	25.75	1"	18	34	66	0.251	48
PEXF6FIE03232	32X1 1/4"	25.75	1 1/4"	19	34	71	0.279	40

\*This item requires special ordering. Please consult with a salesperson for the estimated lead time.

# PEX MULTI LAYER PIPES AND FITTINGS



COMPLY WITH BS EN ISO 21003-1:2008  
 BS EN ISO 21003-3:2008  
 BS EN ISO 21003-5:2008  
 AS/NZS 4020:2005  
 SS 375:2015



## F6 PUSH-FIT PEX MI ELBOW

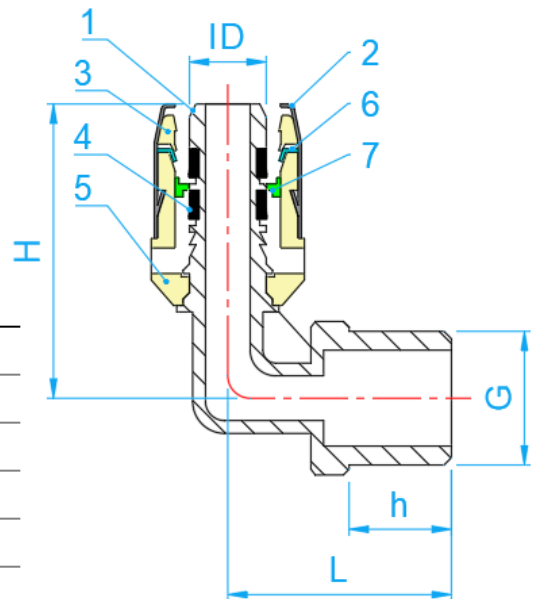

SECTION VIEW

### COMPONENT PARTS

ITEM	PARTS	MATERIAL
1	Body	DZR Brass
2	Collet Retainer	AISI304
3	Spacer	POM
4	Seal Ring	EPDM
5	Collet	PPSU (Polyphenylene Sulfone Resin)
6	Grab Ring	AISI316
7	Indicator Ring	HDPE (High Density Polyethylene)

### DIMENSIONS

SKU	SIZE (mmxinch)	ID (mm)	R BSPT (inch)	h (mm)	L (mm)	H (mm)	WEIGHT (kg)	PCS/CTN
PEXF6MIE01616	16X1/2"	11.80	1/2"	14.0	35	46.0	0.074	144
PEXF6MIE01620	16X3/4"	11.80	3/4"	15.0	36	48.5	0.093	96
PEXF6MIE02016	20X1/2"	15.80	1/2"	14.0	37	47.0	0.093	80
PEXF6MIE02020	20X3/4"	15.80	3/4"	15.0	38	50.0	0.112	80
PEXF6MIE02520	25X3/4"	19.75	3/4"	15.0	42	56.0	0.153	96
PEXF6MIE02525	25X1"	19.75	1"	16.0	43	60.0	0.196	80
PEXF6MIE03220 *	32X3/4"	25.75	3/4"	15.0	45	62.0	-	-
PEXF6MIE03225	32X1"	25.75	1"	16.0	46	65.0	0.252	48
PEXF6MIE03232	32X1 1/4"	25.75	1 1/4"	19.5	45	68.5	0.290	40

\*This item requires special ordering. Please consult with a salesperson for the estimated lead time.

# PEX MULTI LAYER PIPES AND FITTINGS



COMPLY WITH BS EN ISO 21003-1:2008  
 BS EN ISO 21003-3:2008  
 BS EN ISO 21003-5:2008  
 BS EN 12165:2016  
 AS/NZS 4020:2005  
 SS 375:2015



## F6 PUSH-FIT PEX EQUAL TEE

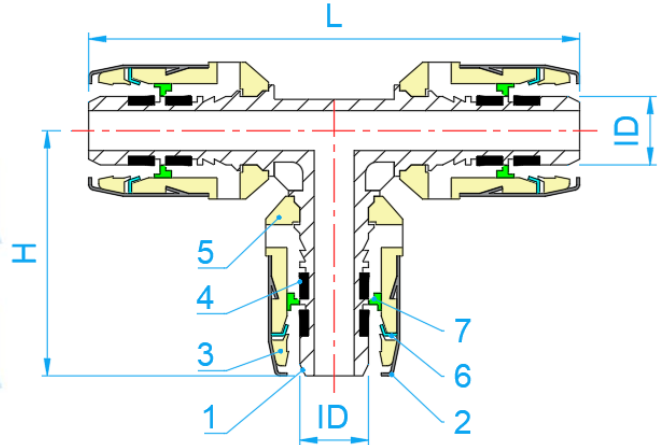

### COMPONENT PARTS

ITEM	PARTS	MATERIAL
1	Body	DZR Brass
2	Collet Retainer	AISI304
3	Spacer	POM
4	Seal Ring	EPDM
5	Collet	PPSU (Polyphenylene Sulfone Resin)
6	Grab Ring	AISI316
7	Indicator Ring	HDPE (High Density Polyethylene)

SECTION VIEW

### DIMENSIONS

SKU	SIZE (mm)	ID (mm)	L (mm)	H (mm)	WEIGHT (kg)	PCS/CTN
PEXF6ET016	16	11.80	86	43	0.117	96
PEXF6ET020	20	15.80	93	47	0.174	72
PEXF6ET025	25	19.75	106	53	0.270	48
PEXF6ET032	32	25.75	125	63	0.451	24

# PEX MULTI LAYER PIPES AND FITTINGS



COMPLY WITH BS EN ISO 21003-1:2008  
 BS EN ISO 21003-3:2008  
 BS EN ISO 21003-5:2008  
 BS EN 12165:2016  
 AS/NZS 4020:2005  
 SS 375:2015



## F6 PUSH-FIT PEX REDUCING TEE

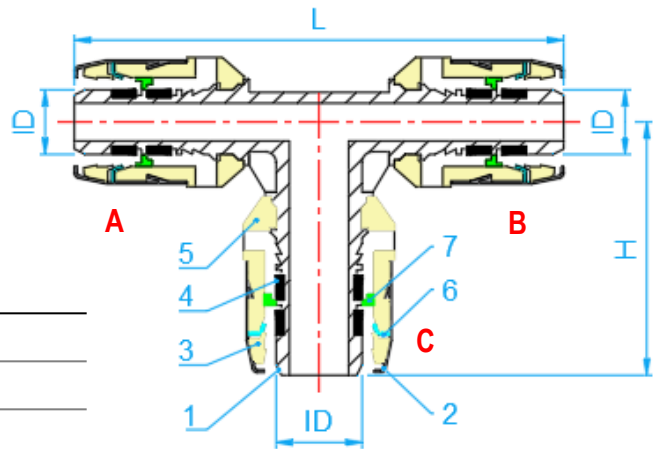

SECTION VIEW

### COMPONENT PARTS

ITEM	PARTS	MATERIAL
1	Body	DZR Brass
2	Collet Retainer	AISI304
3	Spacer	POM
4	Seal Ring	EPDM
5	Collet	PPSU (Polyphenylene Sulfone Resin)
6	Grab Ring	AISI316
7	Indicator Ring	HDPE (High Density Polyethylene)

### DIMENSIONS

SKU (A*B*C)	SIZE (A*C*B)	ID (mm)	ID1 (mm)	ID2 (mm)	L (mm)	H (mm)	WEIGHT (kg)	PCS/CTN
PEXF6RT0161620	16X20X16	11.80	11.80	15.80	91	47.0	0.146	72
PEXF6RT0161625	16X25X16	11.80	11.80	19.75	96	53.0	0.173	60
PEXF6RT0201616	20X16X16	15.80	11.80	11.80	88	45.0	0.138	72
PEXF6RT0201620	20X20X16	15.80	11.80	15.80	92	47.0	0.157	72
PEXF6RT0202016	20X16X20	15.80	15.80	11.80	93	47.0	0.156	72
PEXF6RT0201625 *	20X25X16	15.80	11.80	19.75	98	53.0	-	-
PEXF6RT0202025 *	20X25X20	15.80	15.80	19.75	99	53.0	-	-
PEXF6RT0202032 *	20X32X20	15.80	15.80	25.75	106	60.0	-	-
PEXF6RT0251616 *	25X16X16	19.75	11.80	11.80	93	47.0	-	-
PEXF6RT0252016 *	25X16X20	19.75	15.80	11.80	95	47.0	-	-
PEXF6RT0252516	25X16X25	19.75	19.75	11.80	100	47.0	0.215	60
PEXF6RT0251620 *	25X20X16	19.75	11.80	15.80	97	49.0	-	-
PEXF6RT0252020	25X20X20	19.75	15.80	15.80	98	49.0	0.208	60

\*This item requires special ordering. Please consult with a salesperson for the estimated lead time.

# PEX MULTI LAYER PIPES AND FITTINGS



COMPLY WITH BS EN ISO 21003-1:2008  
 BS EN ISO 21003-3:2008  
 BS EN ISO 21003-5:2008  
 BS EN 12165:2016  
 AS/NZS 4020:2005  
 SS 375:2015



## F6 PUSH-FIT PEX REDUCING TEE

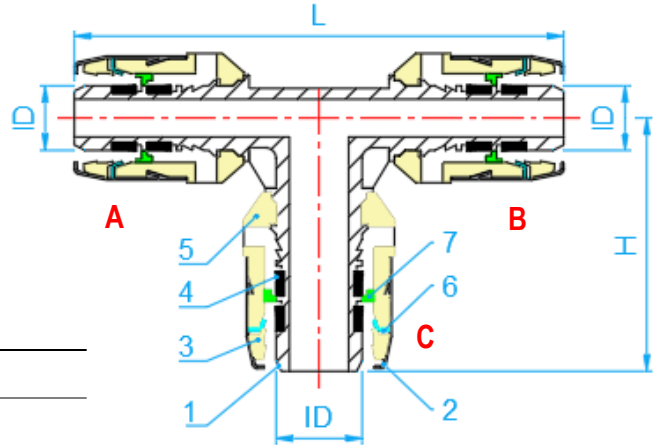

SECTION VIEW

### COMPONENT PARTS

ITEM	PARTS	MATERIAL
1	Body	DZR Brass
2	Collet Retainer	AISI304
3	Spacer	POM
4	Seal Ring	EPDM
5	Collet	PPSU (Polyphenylene Sulfone Resin)
6	Grab Ring	AISI316
7	Indicator Ring	HDPE (High Density Polyethylene)

### DIMENSIONS

SKU (A*B*C)	SIZE (A*C*B)	ID (mm)	ID1 (mm)	ID2 (mm)	L (mm)	H (mm)	WEIGHT (kg)	PCS/CTN
PEXF6RT0252520	25X20X25	19.75	19.75	15.80	103	49.0	0.236	56
PEXF6RT0251625 *	25X25X16	19.75	11.80	19.75	102	53.0	-	-
PEXF6RT0252025 *	25X25X20	19.75	15.80	19.75	104	53.0	-	-
PEXF6RT0252532 *	25X32X25	19.75	19.75	25.75	106	60.0	-	-
PEXF6RT0322516 *	32X16X25	25.75	19.75	11.80	105	50.0	-	-
PEXF6RT0323216	32X16X32	25.75	25.75	11.80	110	50.0	0.330	48
PEXF6RT0322020 *	32X20X20	25.75	15.80	15.80	104	53.0	-	-
PEXF6RT0322520	32X20X25	25.75	19.75	15.80	109	53.0	0.298	48
PEXF6RT0323216	32X16X32	25.75	25.75	11.80	112	51.5	0.310	48
PEXF6RT0323220	32X20X32	25.75	25.75	15.80	114	53.0	0.350	48
PEXF6RT0322525	32X25X25	25.75	19.75	19.75	114	59.0	0.333	32
PEXF6RT0323225	32X25X32	25.75	25.75	19.75	120	59.0	0.390	24

\*This item requires special ordering. Please consult with a salesperson for the estimated lead time.

# PEX MULTI LAYER PIPES AND FITTINGS



COMPLY WITH BS EN ISO 21003-1:2008  
 BS EN ISO 21003-3:2008  
 BS EN ISO 21003-5:2008  
 BS EN 12165:2016  
 AS/NZS 4020:2005  
 SS 375:2015



## F6 PUSH-FIT PEX FITTEE

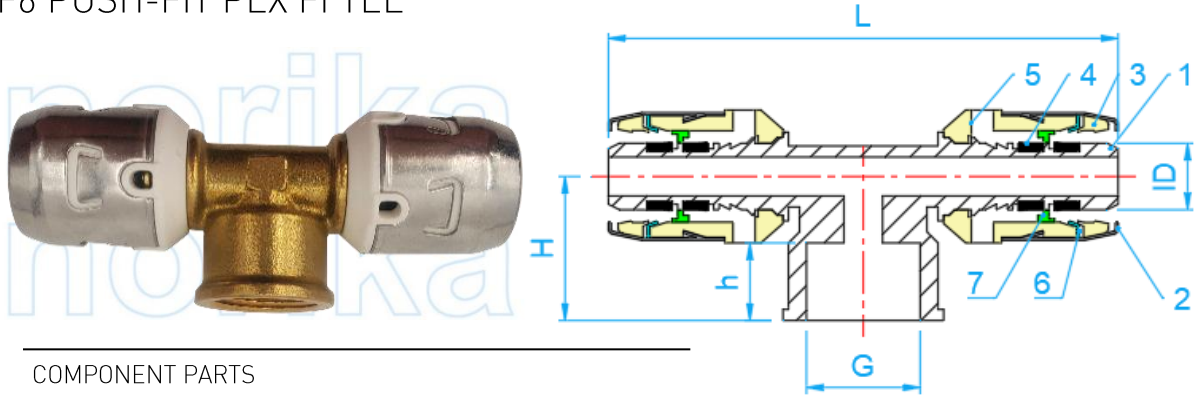

SECTION VIEW

### COMPONENT PARTS

ITEM	PARTS	MATERIAL
1	Body	DZR Brass
2	Collet Retainer	AISI304
3	Spacer	POM
4	Seal Ring	EPDM
5	Collet	PPSU (Polyphenylene Sulfone Resin)
6	Grab Ring	AISI316
7	Indicator Ring	HDPE (High Density Polyethylene)

### DIMENSIONS

SKU	SIZE (mmxinch)	ID (mm)	G BSPT (inch)	h (mm)	L (mm)	H (mm)	WEIGHT (kg)	PCS/CTN
PEXF6FIT01616	16X1/2"	11.80	1/2"	14	94	26	0.118	110
PEXF6FIT01620 *	16X3/4"	11.80	3/4"	15	99	27	-	-
PEXF6FIT02016	20X1/2"	15.80	1/2"	14	97	27	0.122	90
PEXF6FIT02020 *	20X3/4"	15.80	3/4"	15	102	28	-	-
PEXF6FIT02516	25X1/2"	19.75	1/2"	14	107	29	0.220	60
PEXF6FIT02520 *	25X3/4"	19.75	3/4"	15	112	30	-	-
PEXF6FIT03216 *	32X1/2"	25.75	1/2"	14	118	32	-	-
PEXF6FIT03220 *	32X3/4"	25.75	3/4"	15	123	33	-	-
PEXF6FIT03225 *	32X1"	25.75	1"	16	131	34	-	-

\*This item requires special ordering. Please consult with a salesperson for the estimated lead time.

# PEX MULTI LAYER PIPES AND FITTINGS



COMPLY WITH BS EN ISO 21003-1:2008  
 BS EN ISO 21003-3:2008  
 BS EN ISO 21003-5:2008  
 BS EN 12165:2016  
 AS/NZS 4020:2005  
 SS 375:2015



## F6 PUSH-FIT PEX MI TEE

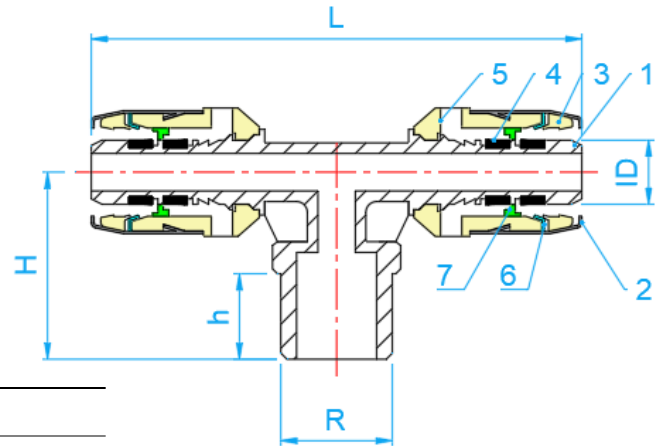
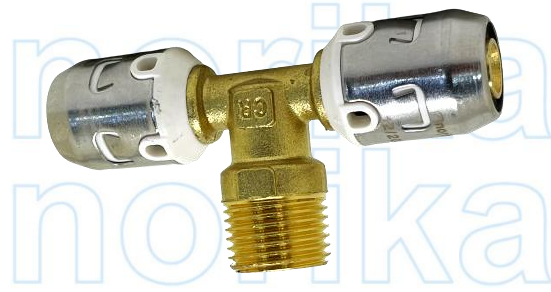

SECTION VIEW

### COMPONENT PARTS

ITEM	PARTS	MATERIAL
1	Body	DZR Brass
2	Collet Retainer	AISI304
3	Spacer	POM
4	Seal Ring	EPDM
5	Collet	PPSU (Polyphenylene Sulfone Resin)
6	Grab Ring	AISI316
7	Indicator Ring	HDPE (High Density Polyethylene)

### DIMENSIONS

SKU	SIZE (mmxinch)	ID (mm)	R BSPT (inch)	h (mm)	L (mm)	H (mm)	WEIGHT (kg)	PCS/CTN
PEXF6MIT01616	16X1/2"	11.80	1/2"	14	92	35	0.115	100
PEXF6MIT01620	16X3/4"	11.80	3/4"	15	97	36	0.140	100
PEXF6MIT02016 *	20X1/2"	15.80	1/2"	14	94	37	-	-
PEXF6MIT02020 *	20X3/4"	15.80	3/4"	15	100	38	-	-
PEXF6MIT02516 *	25X1/2"	19.75	1/2"	14	107	41	-	-
PEXF6MIT02520	25X3/4"	19.75	3/4"	15	112	42	0.231	48
PEXF6MIT03220 *	32X3/4"	25.75	3/4"	15	123	45	-	-
PEXF6MIT03225 *	32X1"	25.75	1"	16	130	46	-	-

\*This item requires special ordering. Please consult with a salesperson for the estimated lead time.

# PEX PIPES AND FITTINGS

COMPLY WITH BS EN ISO 21003-1:2008  
 BS EN ISO 21003-3:2008  
 SS 375:2015



## F6 PUSH-FIT PEX BALL VALVE

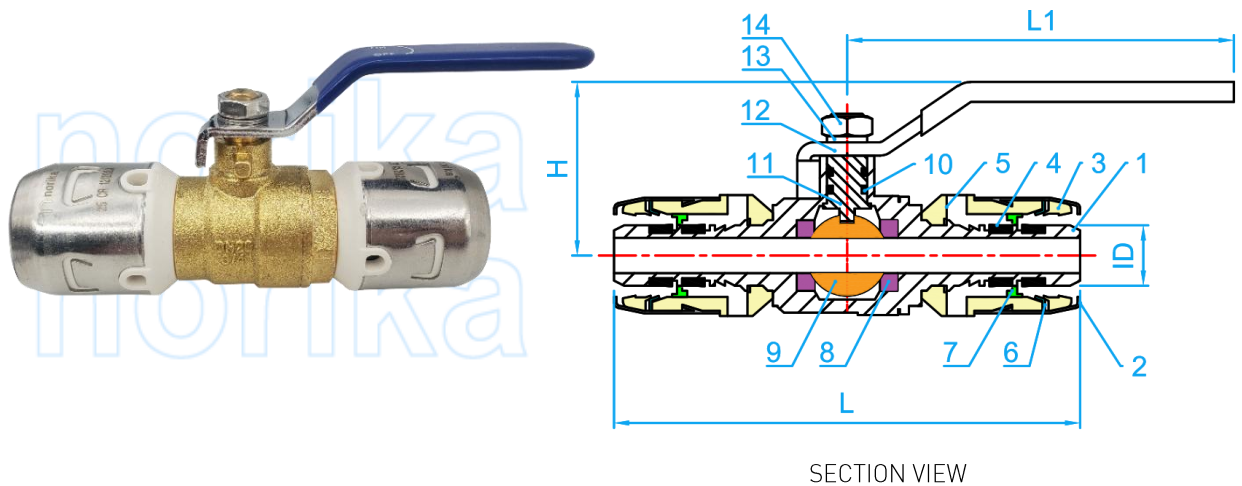

SECTION VIEW

COMPONENT PARTS		
ITEM	PARTS	MATERIAL
1	Body	DZR Brass
2	Collet Retainer	AISI304
3	Spacer	POM
4	Seal Ring	EPDM
5	Collet	PPSU (Polyphenylene Sulfone Resin)
6	Grab Ring	AISI316
7	Indicator Ring	HDPE (High Density Polyethylene)

COMPONENT PARTS		
ITEM	PARTS	MATERIAL
8	Seat	PTFE
9	Ball	DZR Brass
10	O-ring	EPDM
11	Stem	DZR Brass
12	Handle	Q235
13	Spring Washer	65Mn Spring Steel
14	Nut	AISI304

### DIMENSIONS

SKU	SIZE (mm)	ID (mm)	L (mm)	L1 (mm)	H (mm)	WEIGHT (kg)	PCS/CTN
PEXF6BV016	16	11.80	92.3	73.5	38	0.156	120
PEXF6BV020	20	15.80	100.0	84.0	43	0.236	96
PEXF6BV025	25	19.75	114.5	84.0	46	0.324	72

# PEX MULTI LAYER PIPES AND FITTINGS



COMPLY WITH BS EN ISO 21003-1:2008  
 BS EN ISO 21003-3:2008  
 BS EN ISO 21003-5:2008  
 AS/NZS 4020:2005  
 SS 375:2015



## F6 PUSH-FIT PEX FI WALLPLATE ELBOW

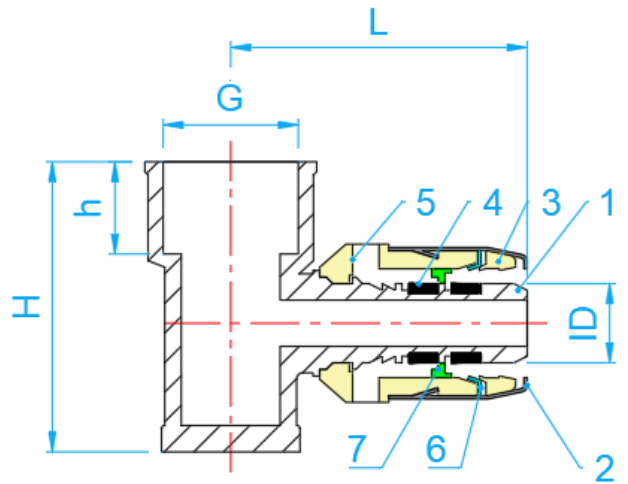

SECTION VIEW

### COMPONENT PARTS

ITEM	PARTS	MATERIAL
1	Body	DZR Brass
2	Collet Retainer	AISI304
3	Spacer	POM
4	Seal Ring	EPDM
5	Collet	PPSU (Polyphenylene Sulfone Resin)
6	Grab Ring	AISI316
7	Indicator Ring	HDPE (High Density Polyethylene)

### DIMENSIONS

SKU	SIZE (mmxinch)	ID (mm)	h (mm)	L (mm)	H (mm)	WEIGHT (kg)	PCS/CTN
PEXF6FE016	16X1/2"	11.80	15	47	43	0.082	144
PEXF6FE02016	20X1/2"	15.80	15	48	43	0.127	120

# PEX PIPES AND FITTINGS

COMPLY WITH BS EN ISO 21003-1:2008  
 BS EN ISO 21003-3:2008  
 SS 375:2015



## F6 PUSH-FIT PEX ASSEMBLY DOUBLE FLANGE ELBOW

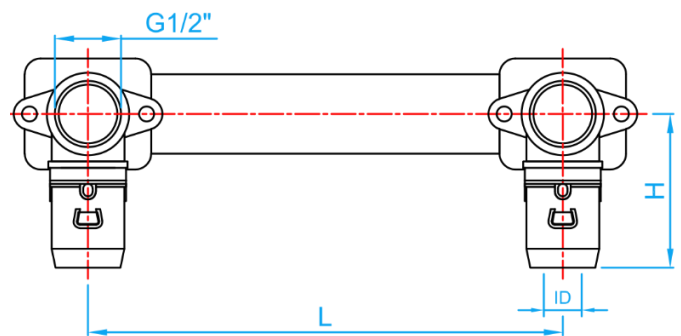

SIDE VIEW

### DIMENSIONS

SKU	SIZE (mmxinch)	ID (mm)	L (mm)	H (mm)	WEIGHT (kg)	PCS/CTN
PEXF6FE016S	16X1/2"	11.8	150	49.5	0.223	16
PEXF6FE02016S *	20X1/2"	15.8	150	51.0	-	-

\*This item requires special ordering. Please consult with a salesperson for the estimated lead time.

# PEX MULTI LAYER PIPES AND FITTINGS

COMPLY WITH BS EN ISO 21003-1:2008  
 BS EN ISO 21003-3:2008  
 BS EN ISO 21003-5:2008  
 BS EN 12165:2016  
 AS/NZS 4020:2005  
 SS 375:2015



## F5 PRESSFIT X F6 PUSH-FIT PEX REDUCER

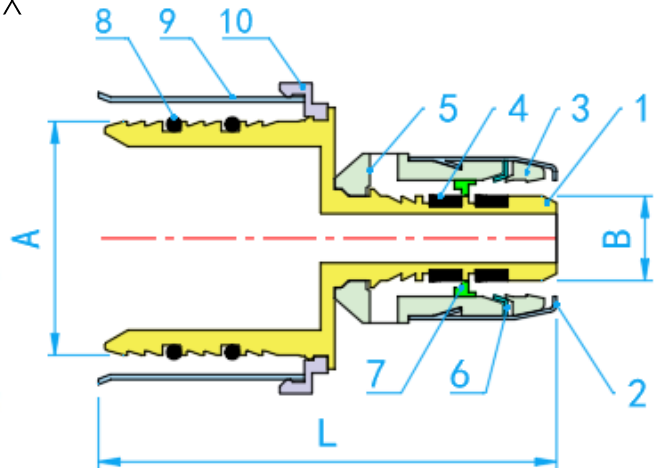

SIDE VIEW

### COMPONENT PARTS

ITEM	PARTS	MATERIAL
1	Body	DZR Brass
2	Collet Retainer	AISI304
3	Spacer	POM
4	Seal Ring	EPDM
5	Collet	PPSU (Polyphenylene Sulfone Resin)
6	Grab Ring	AISI316
7	Indicator Ring	HDPE (High Density Polyethylene)
8	O Ring	EPDM
9	Sleeve	AISI304
10	Plastic Gasket	PE

### DIMENSIONS

SKU	SIZE A×B (mm)	A (mm)	B (mm)	L (mm)	WEIGHT (kg)	PCS/CTN
PEXF6RS04032	40×32	31.75	25.75	85.0	0.284	42
PEXF6RS05020	50×20	40.75	15.80	93.5	0.290	38

# PEX MULTI LAYER PIPES AND FITTINGS

COMPLY WITH BS EN ISO 21003-1:2008  
 BS EN ISO 21003-3:2008  
 BS EN ISO 21003-5:2008  
 BS EN 12165:2016  
 AS/NZS 4020:2005  
 SS 375:2015



## F5 PRESSFIT X F6 PUSH-FIT PEX REDUCING TEE

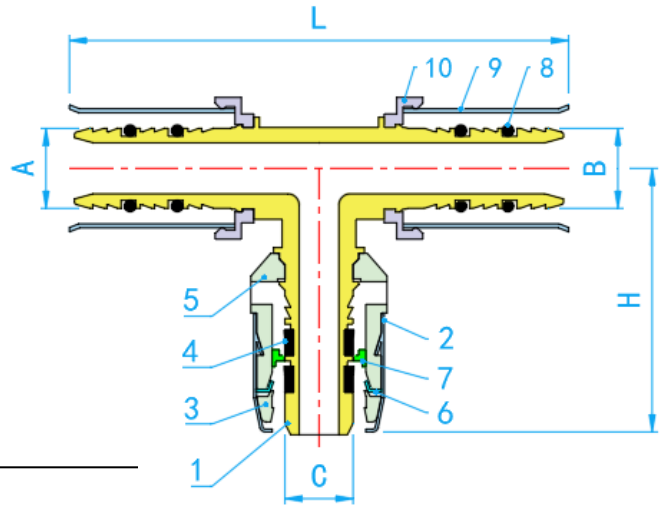

SIDE VIEW

### COMPONENT PARTS

ITEM	PARTS	MATERIAL
1	Body	DZR Brass
2	Collet Retainer	AISI304
3	Spacer	POM
4	Seal Ring	EPDM
5	Collet	PPSU (Polyphenylene Sulfone Resin)
6	Grab Ring	AISI316
7	Indicator Ring	HDPE (High Density Polyethylene)
8	O Ring	EPDM
9	Sleeve	AISI304
10	Plastic Gasket	PE

### DIMENSIONS

SKU	SIZE A×B×C (mm)	A (mm)	B (mm)	C (mm)	L (mm)	H (mm)	WEIGHT (kg)	PCS/CTN
PEXF6RT0404025	40×40×25	31.75	31.75	19.75	128	63	0.485	24
PEXF6RT0404032	40×40×32	31.75	31.75	25.75	136	68	0.556	20



## Built For Water



### Main Office

#### (Kitchener Road)

133 Kitchener Road,  
Singapore 208517  
Official Operating Hours:  
Mon – Fri : 8:00am – 5:30pm  
Sat, Sun & PH: Closed

Fax: (65) 6296 7195 (Local)  
Fax: (65) 6392 1280  
(International)

### North Office

#### (Admiralty Street)

North Link Building,  
No.10 Admiralty Street,  
#02-45,  
Singapore 757695  
Official Operating Hours:  
Mon – Fri : 8:00am –  
5:30pm  
Sat, Sun & PH: Closed

Fax: (65) 6555 5710

Scan to Contact Us:

