

ULTRASONIC MODBUS WATER METER FLANGE ENDED

COMPLY WITH ISO 4064-1
ISO 4064-2

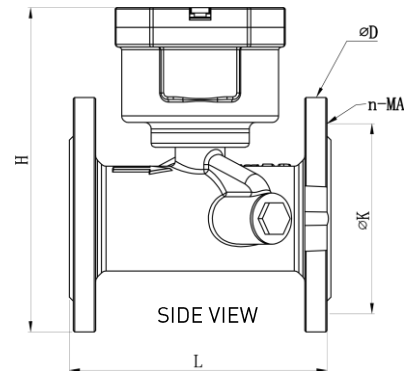
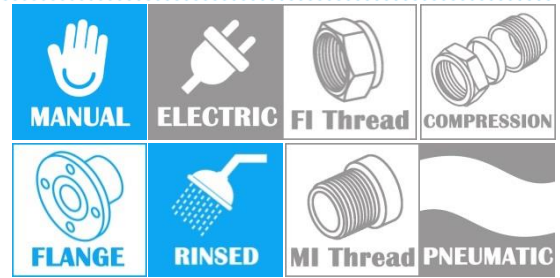

Wire material used: RS485 bus RVV4x (0.2-1mm²) shielded wire.

STANDARD SPECIFICATIONS

Water Temperature	0°C ≤ t ≤ 30°C
Operating Pressure	≤ 1.6Mpa
Operating Voltage	DC 12 V
Battery Lifespan	6 Years
Communication transmission rate	9600 B/S

COMPONENT PARTS

ITEM	PARTS	MATERIAL
1	Lid	Epoxy Coated Ductile Iron
2	Sealed Register	PC+ABS+POM
3	Communications	/
4	Body	Epoxy Coated Ductile Iron
5	Impeller	ABS
6	Flange	Epoxy Coated Ductile Iron

FLOW RATE SPECIFICATIONS

SKU	SIZE (mm)	QS Maximum flow rate [m ³ /h]	QP Nominal flow rate [m ³ /h]	Qt Transitional flow rate [m ³ /h]	Qmin Minimum flow rate [m ³ /h]
WMSUN050F	50	31.250	25.0	0.160	0.100
WMSUN065F	65	50.000	40.0	0.256	0.160
WMSUN080F	80	78.750	63.0	0.403	0.252
WMSUN100F	100	125.000	100.0	0.640	0.400
WMSUN150F	150	312.500	250.0	1.600	1.000
WMSUN200F	200	500.000	400.0	2.560	1.600
WMSUN250F	250	787.500	630.0	4.030	2.520
WMSUN300F	300	1250.000	1000.0	6.400	4.000
WMSUN350F	350	3125.000	1600.0	16.000	10.000
WMSUN400F	400	3125.000	1600.0	16.000	10.000

DIMENSIONS

SKU	L(mm)	D(mm)	H(mm)	K(mm)	N-Bolt(mm)	B(mm)	WEIGHT(kg)	PCS/CTN
WMSUN050F	200	165	219	125	4-M16	120	9.80	1
WMSUN065F	200	185	231	145	4-M16	120	11.40	1
WMSUN080F	225	200	249	160	8-M16	120	13.20	1
WMSUN100F	248	220	258	180	8-M16	120	16.30	1
WMSUN150F	300	285	297	240	8-M20	120	26.80	1
WMSUN200F	350	340	445	295	12-M20	120	-	1
WMSUN250F	450	405	495	355	12-M24	120	-	1
WMSUN300F	500	460	555	410	12-M24	120	-	1
WMSUN350F	550	520	595	470	16-M24	120	-	1
WMSUN400F	600	580	650	525	16-M27	120	-	1

- *1) Ensure the water meter is installed in the correct water flow direction.
- 2) Always select the correct size and specification for the meter.
- 3) These water meters can be installed in either horizontal or vertical positions, but the correct installation guidelines must be strictly followed. Failure to comply will result in damage to the meter and void the warranty.
- 4) Use exclusively for indoor installations.

Guideline for correct installations of ultrasonic modbus water meter (Flanged End)

Figure 1 – Horizontal Installation

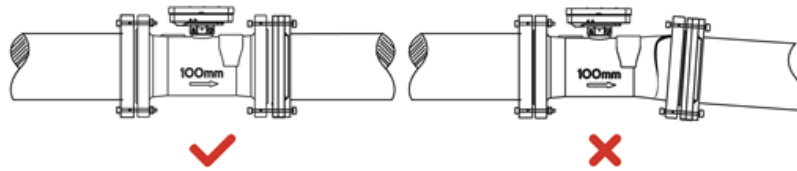

If the reserved position for the meter on the welded flange is too large or if the flange is welded unevenly at an angle relative to the meter flange, do not forcibly tighten the bolts. Doing so may cause the meter body to break. The correct approach is to remove and reinstall the meter properly

Figure 2 – Horizontal Installation

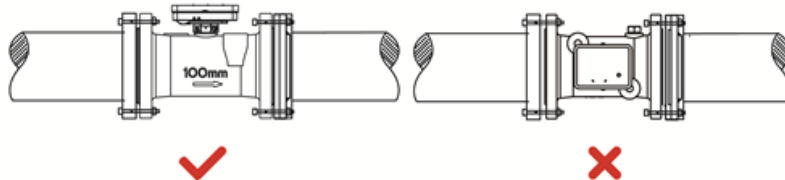

When installing the meter horizontally, the integration instrument should be oriented upwards. If it is oriented to the side, the two transducers may not be on the same horizontal plane, allowing air to accumulate at the higher transducer and causing inaccurate or failed measurements.

Figure 3 - Horizontal Installation



When installed at a U-bend, the meter should be positioned at the lowest point. Air can accumulate at higher points in the pipe, leading to inaccurate or failed measurements.

Figure 4 - Horizontal Installation

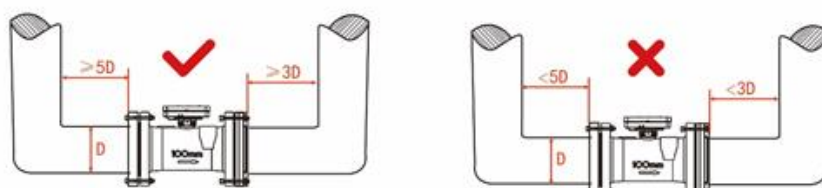

When the meter is installed at a bend, ensure the straight pipe distance upstream of the meter is at least 5 times the pipe diameter, and the straight pipe distance downstream is at least 3 times the pipe diameter. Failure to maintain these distances may result in inaccurate measurements.

Figure 5 - Horizontal Installation

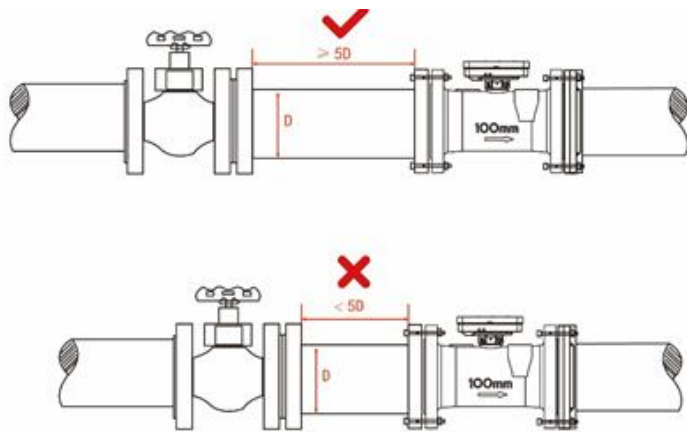

When a valve or other object is installed upstream of the meter, ensure there is a distance of at least 5 times the pipe diameter between the meter and the object. Failure to maintain this distance may result in inaccurate measurements.

Figure 6 - Vertical Installation

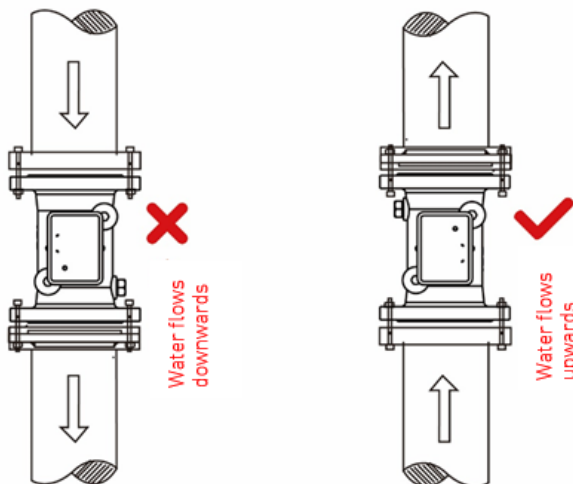

When installing the meter vertically, it must be placed on a straight pipe with water flowing upwards. Air can accumulate in the pipe at higher points due to gravity, leading to incomplete filling of the pipe and resulting in inaccurate or failed measurements.