

BRONZE GATE VALVE SOLDERING END

COMPLY WITH BS EN 12288:2010
BS 5154:1991
AS/NZS4020:2005
BS EN 1982:2008
BS12165:2016

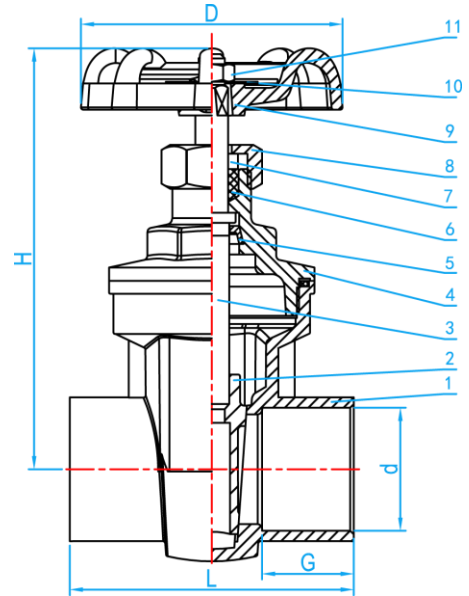

CROSS SECTIONAL VIEW

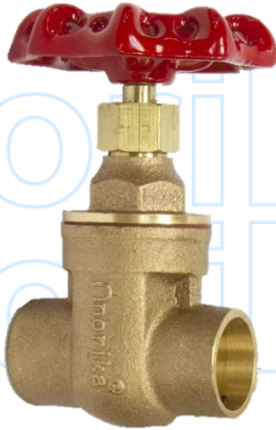
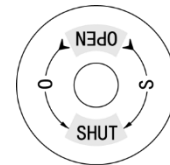

11. Name Plate

COMPONENT PARTS		
ITEMS	PARTS	MATERIAL
1	Body	Bronze
2	Disc	DZR Brass
3	Stem	15-50mm: DZR Brass 65-80mm: AISI304
4	Bonnet	DZR Brass
5	Straining Ring	Brass
6	Packing Nut	Expanded Graphite
7	Gland	AISI304
8	Lock Nut	Brass
9	Hand Wheel	HT150
10	Name Plate	Aluminum Plate
11	Wheel Nut	AISI304

STANDARD SPECIFICATIONS	
Working Pressure	200 Psi
Applicable Medium	Water

DIMENSIONS

SKU	SIZE (mm)	L (mm)	H (mm)	D (mm)	d (mm)	G (mm)	WEIGHT (kg)	PCS/CTN
GVMBLN015	15	43	76	55	15.06	12	0.228	72
GVMBLN020	20	51	85	55	22.07	15.5	0.315	48
GVMBLN025	25	64	95	60	28.07	20.5	0.488	32
GVMBLN035	35	75	113	72	35.09	24	0.768	24
GVMBLN042	42	85	124	72	42.09	27.2	0.995	18
GVMBLN050	50	97	146	80	54.09	33	1.593	12
GVMBLN065	65	118	193	100	67.1	37	2.982	6
GVMBLN080	80	120	200	110	76.1	38	3.500	6