

MAPP GAS & WELDING TORCH

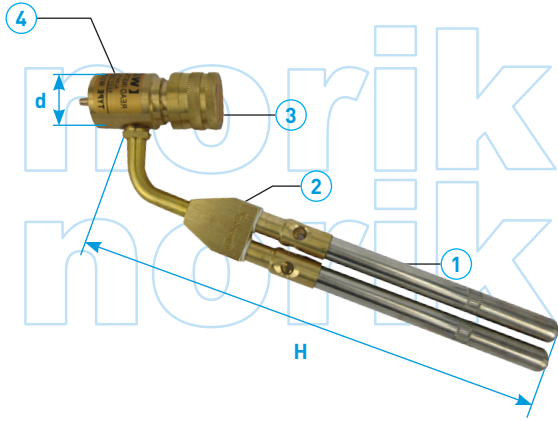

CHARACTERISTIC

- Use together with welding torch, the combustion temperature can reach 1300°C under anaerobic conditions.
- Easy installation & hand held.
- Burns hotter than propane and natural gas.
- Torching no bivinyll and allene, no threat for health, environmental protection.

WELDING TORCH

COMPONENT PARTS

ITEM	PARTS	MATERIAL
1	Burner Tube	Stainless Steel
2	Swivel	Brass
3	Gas Adjustment Knob	Brass
4	Connection Fitting	Brass

MAPP GAS

COMPONENT PARTS

ITEM	PARTS	MATERIAL
1	Body	Steel
2	Tag	Paper
3	Bottle Cap	Plastic

STANDARD SPECIFICATIONS

STOCK CODE	H (mm)	D (mm)	NET WEIGHT	GROSS WEIGHT (KG)
Mapp Gas (Methyl Acetylene & Propadiene)	280	75	16.0 oz	0.80
Welding Torch	260	25	0.40 kg	0.54