

PPR PIPE WELDING MACHINE

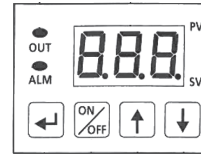

CONTROL PANEL

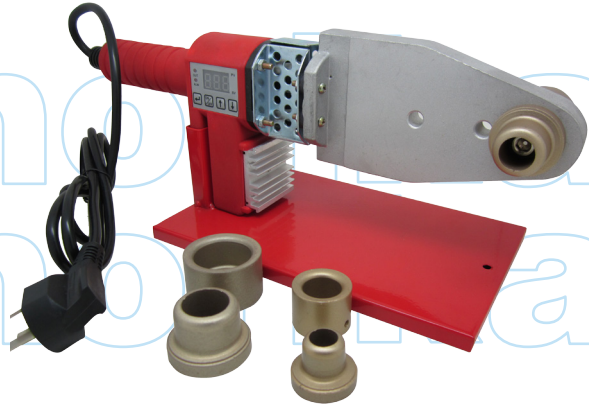
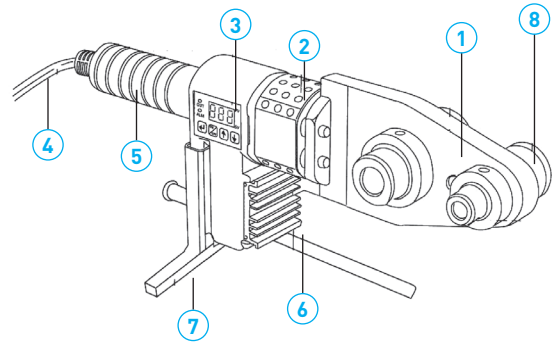
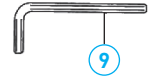

3-D VIEW

STANDARD SPECIFICATIONS

VOLTAGE RATING	230 V
POWER RATING	800 w / 50 Hz
CURRENT RATING	3.75A
WORKING RANGE	DN 20 ~ 63 mm
TEMPERATURE RANGE	50°C ~ 315°C
DIMENSIONS	420 x 175 x 125 mm
WEIGHT	3.18 kg

COMPONENT PARTS

ITEM	PARTS
1	Heating Plate
2	Power Circuit Cooling Chamber
3	Control And Regulation Panel
4	Power Supply Cable
5	Hand Shank
6	Electronic Circuit Fin Cooler
7	Seat
8	Adapters
9	Hexagon Spanner

WELDING TABLE FOR P.P TUBES

TUBO		HEATING	ASSEMBLY	SETTING AND COOLING	
DIAMETER (mm)	THICKNESS (mm)	TIME (sec)	MAX TIME (sec)	FIXED TUBES (sec)	FREE TUBES (sec)
16	2	5	4	5	2
20	2.5	5	4	5	2
25	2.7	7	4	7	2
32	3	8	6	8	4
40	3.7	12	6	12	4
50	4.6	18	6	18	4
63	3.6	24	8	24	6

* Above heating time based on 260°C.

* When temperature reaches setting, please wait for 15 mins to allow temperature to stabilized before use.