

——— Sensor and controller ———

- Flow
- pressure
- temperature
- level
- position



Name of Reliability in Quality Accessories

Electronic Liquid Level Sensor M anual

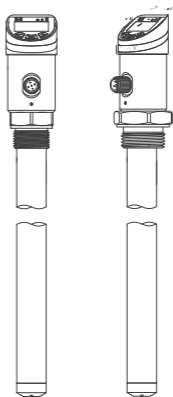

Purpose of product application

The 500 Series sensor (switch) has two switch outputs and one analog output.



danger

The sensor (switch) can only be used in the specified application range.

The temperature range must be within the permissible range. Do not exceed the rated pressure and power load value.

Assembly, commissioning and operation must be carried out in accordance with applicable national and local safety instructions.

The switch is designed to be used as a safety device for pressurizing the system in accordance with "Pressure Equipment Directive 97/23 / EC(PED)".

Standard

The standards applied during development, manufacturing and configuration are listed in the CE Compliance and manufacturer declarations.

Quality assurance

Our scope of delivery and service is subject to legal warranties and warranty periods.

Warranty clause

We guarantee that the functions and materials of the dual pressure switch meet the statutory requirements under normal operation and maintenance conditions.

Security of loss

Such as:

- Incorrect use,
- Incorrect installation
- Incorrect operation or operation in violation of the provisions of this operation manual.

No liability shall be assumed for any damage resulting therefrom or consequential.

Safety instruction

Safety instructions are intended to protect users from dangerous situations and /or prevent material damage.

In the operating instructions, the severity of the potential risk can be indicated by the following signal words:



danger

An imminent danger to the user. Failure to comply may result in fatal injury.



warning

An identifiable hazard.

Failure to comply may result in fatal injury and damage to equipment or plant parts.



caution

It means a danger.

Non-compliance may result in minor injury and material damage to the sensor (switch) and/or plant.



important

Information that is important to the user.



Deal with

Sensors (switches) must be handled correctly in accordance with national or local regulations for electrical/electronic equipment.

Sensors (switches) cannot be disposed of with household waste!

Product characteristics

The all-metal casing design, with a highlighted LED digital display, enables the product line to be used in a variety of industrial applications. The three-button design and menu make the product more convenient to use, and a variety of connection methods can fully meet various specific installation needs. The device, which can rotate at 330°, guarantees the best viewing Angle in different mounting modes.

Switching function

If the switch is higher or lower than the set switching limit (SP, rP), its switching state is changed. The following switch functions can be selected:

- Hysteresis function normally open: = [Hno] (→ Figure 1)
- Hysteresis function normally closed: = [Hnc] (→ Figure 1)

First set the switch point: (SP), Then set the reset point: (rP).

If SP changes again, the hysteresis will change with it.

- Window function usually open: = [Fno] (→ Figure 2)
- Window function normally closed: = [Fnc] (→ Figure 2)

The width of the window can be set by the difference between SP and rP.

SP = Upper limit value, rP = Lower limit value.

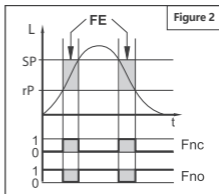
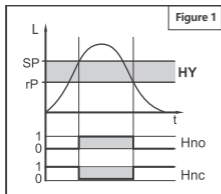

L = level; HY = lag; FE = window

Install

Safety instructions are intended to protect users from dangerous situations and/or prevent material damage. In the operating instructions, the severity of the potential risk can be indicated by the following signal words:



caution

Vibration and violent vibration must be avoided during transportation. Even if the sensor (switch) housing is not damaged, internal components can also break down and cause failure.



danger

Sensors (switches) should only be installed in systems that do not exceed the maximum pressure P_{max} (see type label).
Install sensors (switches) only when power is off (electric, hydraulic/pneumatic).

Panel description

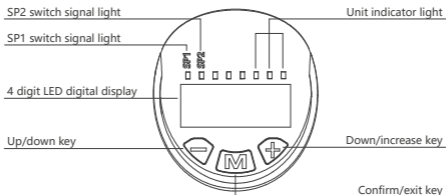

Electrical connection

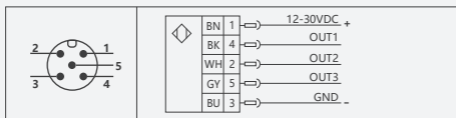

Two-way switch /IO-Link/ frequency + one-way analog

color	stitch	Instructions
BN	1	power supply (+)
BU	3	power supply (-)
BK	4 (OUT1)	SP1 Switch PNP (factory default) SP1 Switch NPN IO-Link Frequency (full scale 100Hz)
WH	2 (OUT2)	SP2 Switch PNP (factory default) SP2 Switch NPN
GY	5 (OUT3)	4-20mA (factory default) 1-5V 0-10V

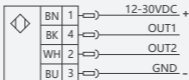

Two way switch/frequency

color	stitch	Instructions
BN	1	power supply (+)
BU	3	power supply (-)
BK	4 (OUT1)	SP1 Switch PNP (factory default) SP1 Switch NPN Frequency (full scale 100Hz)
WH	2 (OUT2)	SP2 Switch PNP (factory default) SP2 Switch NPN

One switch /IO-Link/ frequency + one analog

color	stitch	Instructions
BN	1	power supply (+)
BU	3	power supply (-)
BK	4 (OUT1)	SP1 Switch PNP (factory default) SP1 Switch NPN IO-Link Frequency (full scale 100Hz)
WH	2 (OUT2)	4-20mA (factory default) 1-5v 0-10v

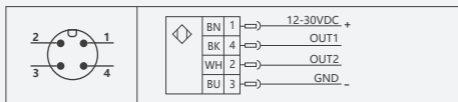

RS485

color	stitch	Instructions
BN	1	power supply (+)
BU	3	power supply (-)
BK	4 (OUT1)	RS485(B)
WH	2 (OUT2)	RS485(A)

Debugging/operation

Sensors can only be debugged and operated by authorized personnel.



caution

Do not put the switch into operation when the sensor itself or the connecting cable is damaged.

Do not use any sharp, hard objects to make entries. The key may be damaged by something sharp and hard.



warning

Note that the casing surface may become very hot if the operating temperature is high!

Level 1 menu	
sp1	Alarm value of Switch 1 (Factory default value is 0.2% of the range)
	Hold down [+] or [-] for at least 1s. After 1 second: The setting value can be changed: At the press of a button, the value increases; Hold the button down and the value will keep changing.
rp1	Switch 1 Reset value (factory default is SP1-0.5%)
	Hold down [+] or [-] for at least 1s. After 1 second: The setting value can be changed: At the press of a button, the value increases; Hold the button down and the value will keep changing.
sp2	Switch 2 alarm value (factory default value is 0.8% of the range)
	Hold down [+] or [-] for at least 1s. After 1 second: The setting value can be changed: At the press of a button, the value increases; Hold the button down and the value will keep changing.
rp2	Switch 2 Reset value (Factory default value is SP2-0.5%)
	Hold down [+] or [-] for at least 1s. After 1 second: The setting value can be changed: At the press of a button, the value increases; Hold the button down and the value will keep changing.
ofst	Level offset
	Hold down [+] or [-] for at least 1s. After 1 second: The setting value can be changed: At the press of a button, the value increases; Hold the button down and the value will keep changing.
EF	Expand functionality/Open the Level 2 menu
	Press the [M] key to enter the Extended 2 level menu Press [+] to exit.

Level 2 menu	
res	factory data reset
	Hold down [+] to restore factory Settings
ou1	Switch 1 signal: (Factory default is HNO) Hysteresis function: HNO (normally open) /HNC (normally closed) Window function: FNO (normally open) /FNC (normally closed)
	Hold down [+] or [-] for at least 1s. After 1 second: The setting value can be changed: At the press of a button, the value increases; Hold the button down and the value will keep changing.
ou2	Switch 2 signal: (Factory default HNC) Hysteresis function: HNO (normally open) /HNC (normally closed) Window function: FNO (normally open) /FNC (normally closed)
	Hold down [+] or [-] for at least 1s. After 1 second: The setting value can be changed: At the press of a button, the value increases; Hold the button down and the value will keep changing.
ds1	The opening delay of OUT1. (The factory default is 0s)
	Hold down [+] or [-] for at least 1s. After 1 second: The setting value can be changed: At the press of a button, the value increases; Hold the button down and the value will keep changing.
dr1	OUT1 shutdown delay. (The factory default is 0s)
	Hold + or [-] for at least 1s. After 1 second: The setting value can be changed: At the press of a button, the value increases; Hold the button down and the value will keep changing.
ds2	OUT2's opening delay. (The factory default is 0s)
	Hold down [+] or [-] for at least 1s. After 1 second: The setting value can be changed: At the press of a button, the value increases; Hold the button down and the value will keep changing.

	OUT2 shutdown delay. (The factory default is 0s)
dr2	Hold down [+] or [-] for at least 1s. After 1 second: The setting value can be changed: At the press of a button, the value increases; Hold the button down and the value will keep changing.
	System standard unit of measurement (display)
uni	Hold down [+] or [-] for at least 1s. After 1 second: The setting value can be changed: At the press of a button, the value increases; Hold the button down and the value will keep changing.
	PNP/NPN switch (Factory default is PNP)
P-n	Hold down [+] or [-] for at least 1s. After 1 second: The setting value can be changed: At the press of a button, the value increases; Hold the button down and the value will keep changing.
	System measurement history minimum.
LO	Hold down [+] or [-] for at least 1s. After 1 second: The setting value can be changed: At the press of a button, the value increases; Hold the button down and the value will keep changing.
	The maximum value of system measurement history
HO	Hold down [+] or [-] for at least 1s. After 1 second: The setting value can be changed: At the press of a button, the value increases; Hold the button down and the value will keep changing.
	Switch point damping/process data flow (IO-Link communication) and display. (Factory default: 0.06)
dap	Hold down [+] or [-] for at least 1s. After 1 second: The setting value can be changed: At the press of a button, the value increases; Hold the button down and the value will keep changing.
	Update rate and direction of the display (d1 by default)
dis	Hold down [+] or [-] for at least 1s. After 1 second: The setting value can be changed: At the press of a button, the value increases; if you hold the button down, the value will keep changing. [d1] : The measured value is updated every 10ms [d2] : The measurement is updated every 100ms [d3] : Update measurement every 600ms

	Zero excision value (full scale %) (factory default is 0.5)
zeao	Hold down [+] or [-] for at least 1s. After 1 second: The setting value can be changed: At the press of a button, the value increases; Hold the button down and the value will keep changing.
	Display refresh time: analog 0.1s (factory default is 0.01)
daa	Hold down [+] or [-] for at least 1s. After 1 second: The setting value can be changed: At the press of a button, the value increases; Hold the button down and the value will keep changing.
iout	Output analog switch: Current type: 4-20: (4-20mA) 20-4: (20-4mA) 0-20: (0-20mA) 20-0: (20-0mA) 5V voltage type: 1-5: (1-5V) 5-1: (5-1V) 0-5: (0-5V) 5-0: (5-0V) 10V voltage type: 1-10: (1-10V) 10-1: (10-1V) 0-10: (0-10V) 10-0: (10-0V)
	Hold down [+] or [-] for at least 1s. After 1 second: The setting value can be changed: At the press of a button, the value increases; Hold the button down and the value will keep changing.
	Expand functionality/Open the Level 2 menu
EF	Press the [M] key to enter the Extended 2 level menu Press [+] to exit.

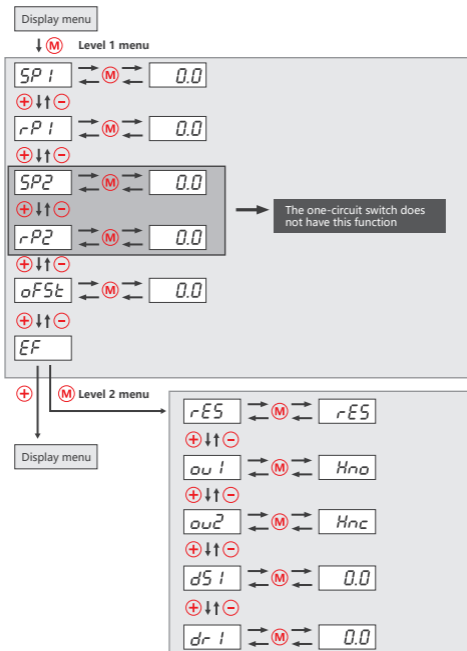

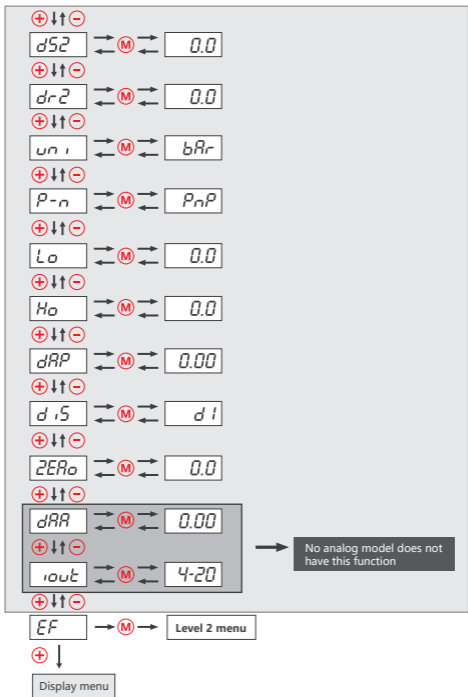

Maintenance/cleaning

Sensors (switches) do not require maintenance.



warning

Periodically check whether the switch is working properly.

If the switch does not work properly, stop the operation immediately.



caution

Use of improper cleaning agent may damage the switch.

The following cleaning agents can be used to clean polycarbonate: mild soap or detergent Isopropyl alcohol

Immediately after cleaning, rinse with water. Do not leave cleaner on the surface of the product. Do not clean products in high heat or direct sunlight.

The following cleaning agents are known to affect the integrity of polycarbonate components and should not be used: ZEP Fast 505, Pinesol, Formula 409

Halogenated solvents (benzene, gasoline, acetone or carbon tetrachloride)

Strong alkalinity

Methyl ethyl ketone

Abrasive substance

disassemble



danger

Only remove the switch in case of power failure (electrical, hydraulic/pneumatic).

Switch disconnection from pressure and power supply must be performed by trained or directed personnel in accordance with the most advanced standards.



warning

Be aware that the surface of the shell may become very hot if the operating temperature is higher!



Name of Reliability in Quality Accessories

—— 传感器与控制器 ——
■流量 ■压力 ■温度 ■液位 ■位置



电子式液位传感器 操作说明

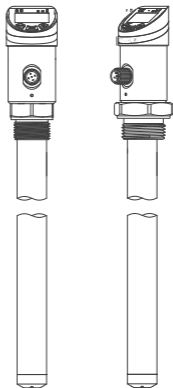

产品应用目的

500系列传感器（开关）有两个开关输出和一个模拟输出。



危险

该传感器（开关）只能用于指定的应用范围。

温度范围必须在允许的范围内。不超过额定压力和电力负荷值。

必须按照适用的国家和地方安全指令进行组装、调试和操作。

开关设计用作的安全装置加压系统根据“压力设备指令97/23 / EC(PED)”。

标准

在开发、制造和配置过程中应用的标准列于CE符合性和制造商声明中。

质量保证

我们的交付和服务范围受法律保证和保修期限的约束。

保证条款

我们保证双压力开关在正常运行和维护条件下的功能和材料符合法定规定。

损失的担保

如:

- 不正确的使用,
- 不正确的安装
- 不正确的操作或操作违反本操作说明书的规定。

由此造成的任何损害或相应的任何损害不承担任何责任。

安全指令

安全说明旨在保护用户免受危险情况和/或防止材料损坏。

在操作说明书中，潜在风险的严重性可以用以下信号词来表示：



危险

指用户面临的迫在眉睫的危险。不遵守可能导致致命的伤害。



警告

指可识别的危险。

不遵守可能导致致命的伤害，并破坏设备或工厂部件。



谨慎

指的是一种危险。

不遵守可能会对传感器（开关）和/或工厂造成轻微伤害和物质损害。



重要的

指对用户至关重要的信息。



处理

传感器（开关）必须按照国家或地方有关电气/电子设备的规定正确处理。

传感器（开关）不能与家庭垃圾一起处理！

产品特点

全金属外壳设计，采用高亮型 LED 数字显示，使得该系列产品能够被用于各种工业场合。三键设计和菜单使产品使用更加方便，多种连接方式可以充分满足各种特定的安装需求。可 330° 旋转的本体能保证在不同安装方式下获得最佳的观察角度。

开关功能

如果开关高于或低于设定的开关限值 (SP、rP)，则会改变其开关状态。

可选择以下开关功能：

- 迟滞功能常开： = [Hno] (→ 图 1).
- 迟滞功能常闭： = [Hnc] (→ 图 1).

首先设定开关点：(SP)，然后设定复位点：(rP)。

如果 SP 再次更改，迟滞也将会随着改变。

- 窗口功能常开： = [Fno] (→ 图 2).
- 窗口功能常闭： = [Fnc] (→ 图 2).

可通过 SP 与 rP 的差值设定窗口的宽度。

SP = 上限值， rP = 下限值。

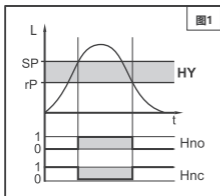

L = 液位； HY = 迟滞； FE = 窗口

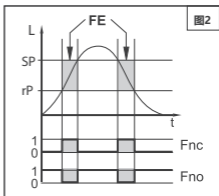

安装

安全说明旨在保护用户免受危险情况和/或防止材料损坏。在操作说明书中，潜在风险的严重性可以用以下信号词来表示：



谨慎

在运输过程中必须避免震动和剧烈震动。即使传感器（开关）外壳没有损坏，内部部件也可能损坏并引起故障。



危险

传感器（开关）只能安装在不超过最大压力 P_{max} 的系统中(请参阅类型标签)。
只有在断电(电、液压/气动)时才安装传感器（开关）。

面板说明

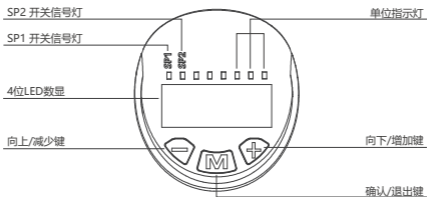

电气连接

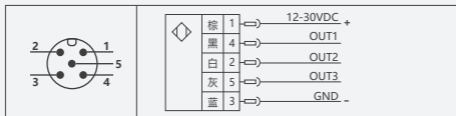

两路开关/IO-Link/频率+一路模拟量

颜色	针脚	说明
棕色	1	电源正 (+)
蓝色	3	电源负 (-)
黑色	4 (OUT1)	SP1 开关PNP (出厂默认) SP1 开关NPN IO-Link 频率 (满量程100Hz)
白色	2 (OUT2)	SP2 开关PNP (出厂默认) SP2 开关NPN
灰色	5 (OUT3)	4-20mA (出厂默认) 1-5V 0-10V

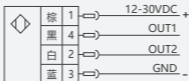

两路开关/频率

颜色	引脚	说明
棕色	1	电源正 (+)
蓝色	3	电源负 (-)
黑色	4 (OUT1)	SP1 开关PNP (出厂默认) SP1 开关NPN 频率 (满量程100Hz)
白色	2 (OUT2)	SP2 开关PNP (出厂默认) SP2 开关NPN

一路开关/IO-Link/频率+一路模拟量

颜色	引脚	说明
棕色	1	电源正 (+)
蓝色	3	电源负 (-)
黑色	4 (OUT1)	SP1 开关PNP (出厂默认) SP1 开关NPN IO-Link 频率 (满量程100Hz)
白色	2 (OUT2)	4-20mA (出厂默认) 1-5v 0-10v

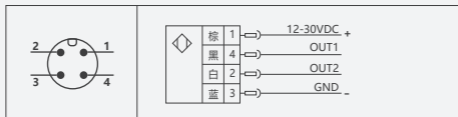

RS485

颜色	针脚	说明
棕色	1	电源正 (+)
蓝色	3	电源负 (-)
黑色	4 (OUT1)	RS485(B)
白色	2 (OUT2)	RS485(A)

调试/操作

传感器只能由授权人员进行调试和操作。



谨慎

当传感器本身或连接电缆损坏时，请勿将开关投入工作。

不要使用任何尖锐、坚硬的物体来制作条目。钥匙可能被尖尖的硬物损坏。



警告

请注意，如果操作温度较高，套管表面可能会变得非常热！

1级菜单	
	开关1报警值 (出厂默认值为量程的0.2%)
sp1	按住 [+] 或 [-] 至少 1s。1 秒后: 设定值可更改: 按一下按钮, 值会递增; 按住按钮不放, 值会持续更改。
	开关1复位值 (出厂默认值为SP1-0.5%)
rp1	按住 [+] 或 [-] 至少 1s。1 秒后: 设定值可更改: 按一下按钮, 值会递增; 按住按钮不放, 值会持续更改。
	开关2报警值 (出厂默认值为量程的0.8%)
sp2	按住 [+] 或 [-] 至少 1s。1 秒后: 设定值可更改: 按一下按钮, 值会递增; 按住按钮不放, 值会持续更改。
	开关2复位值 (出厂默认值为SP2-0.5%)
rp2	按住 [+] 或 [-] 至少 1s。1 秒后: 设定值可更改: 按一下按钮, 值会递增; 按住按钮不放, 值会持续更改。
	液位偏移量
ofst	按住 [+] 或 [-] 至少 1s。1 秒后: 设定值可更改: 按一下按钮, 值会递增; 按住按钮不放, 值会持续更改。
	扩展功能/打开 2 级菜单
EF	按 [M] 键, 进入扩展2级菜单 按 [+] 键, 退出

2级菜单

res	恢复出厂设置
	长按 [+] 恢复出厂设置
ou1	开关1信号：（出厂默认为 HNO） 迟滞功能：HNO（常开）/HNC（常闭） 窗口功能：FNO（常开）/FNC（常闭）
	按住 [+] 或 [-] 至少 1s。1 秒后：设定值可更改： 按一下按钮，值会递增；按住按钮不放，值会持续更改。
ou2	开关2信号：（出厂默认为 HNC） 迟滞功能：HNO（常开）/HNC（常闭） 窗口功能：FNO（常开）/FNC（常闭）
	按住 [+] 或 [-] 至少 1s。1 秒后：设定值可更改： 按一下按钮，值会递增；按住按钮不放，值会持续更改。
ds1	OUT1 的开启延迟。（出厂默认为 0s）
	按住 [+] 或 [-] 至少 1s。1 秒后：设定值可更改： 按一下按钮，值会递增；按住按钮不放，值会持续更改。
dr1	OUT1 的关闭延迟。（出厂默认为 0s）
	按住 + 或 [-] 至少 1s。1 秒后：设定值可更改： 按一下按钮，值会递增；按住按钮不放，值会持续更改。
ds2	OUT2 的开启延迟。（出厂默认为 0s）
	按住 [+] 或 [-] 至少 1s。1 秒后：设定值可更改： 按一下按钮，值会递增；按住按钮不放，值会持续更改。

dr2	OUT2 的关闭延迟。(出厂默认为0s)
	按住 [+] 或 [-] 至少 1s。1 秒后：设定值可更改： 按一下按钮，值会递增；按住按钮不放，值会持续更改。
uni	系统标准测量单位 (显示)
	按住 [+] 或 [-] 至少 1s。1 秒后：设定值可更改： 按一下按钮，值会递增；按住按钮不放，值会持续更改。
P-n	PNP/NPN 切换 (出厂默认为 PNP)
	按住 [+] 或 [-] 至少 1s。1 秒后：设定值可更改： 按一下按钮，值会递增；按住按钮不放，值会持续更改。
L0	系统测量历史最小值。
	按住 [+] 或 [-] 至少 1s。1 秒后：设定值可更改： 按一下按钮，值会递增；按住按钮不放，值会持续更改。
H0	系统测量历史最大值
	按住 [+] 或 [-] 至少 1s。1 秒后：设定值可更改： 按一下按钮，值会递增；按住按钮不放，值会持续更改。
dap	开关点阻尼 / 过程数据流 (IO-Link 通信) 和显示。 (出厂默认为0.06)
	按住 [+] 或 [-] 至少 1s。1 秒后：设定值可更改： 按一下按钮，值会递增；按住按钮不放，值会持续更改。
dis	显示屏的更新速率和方向。(出厂默认为d1)
	按住 [+] 或 [-] 至少 1s。1 秒后：设定值可更改： 按一下按钮，值会递增；按住按钮不放，值会持续更改。 [d1]: 每10ms更新一次测量值 [d2]: 每100ms更新一次测量值 [d3]: 每600ms更新一次测量值

zeao	<p>零位切除值（满量程%）（出厂默认为0.5）</p> <p>按住 [+] 或 [-] 至少 1s。1 秒后：设定值可更改： 按一下按钮，值会递增；按住按钮不放，值会持续更改。</p>
daa	<p>显示屏刷新时间：模拟0.1s（出厂默认为0.01）</p> <p>按住 [+] 或 [-] 至少 1s。1 秒后：设定值可更改： 按一下按钮，值会递增；按住按钮不放，值会持续更改。</p>
iout	<p>输出模拟量切换：</p> <p>电流型：4-20：（4-20mA） 20-4：（20-4mA） 0-20：（0-20mA） 20-0：（20-0mA）</p> <p>5V电压型：1-5：（1-5V） 5-1：（5-1V） 0-5：（0-5V） 5-0：（5-0V）</p> <p>10V电压型：1-10：（1-10V） 10-1：（10-1V） 0-10：（0-10V） 10-0：（10-0V）</p> <p>按住 [+] 或 [-] 至少 1s。1 秒后：设定值可更改： 按一下按钮，值会递增；按住按钮不放，值会持续更改。</p>
EF	<p>扩展功能/打开 2 级菜单</p> <p>按 [M] 键，进入扩展2级菜单 按 [+] 键，退出</p>

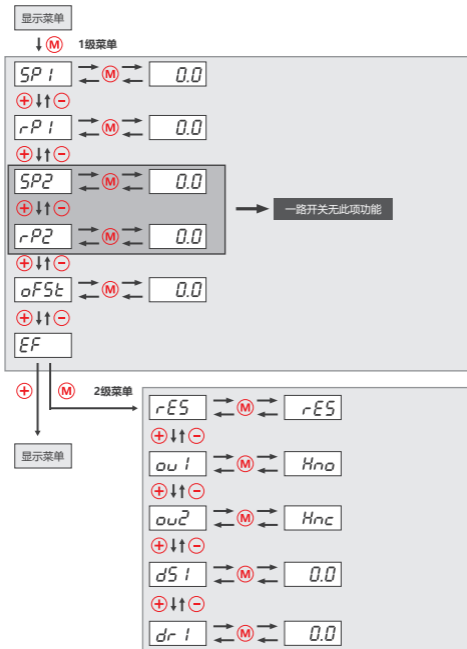

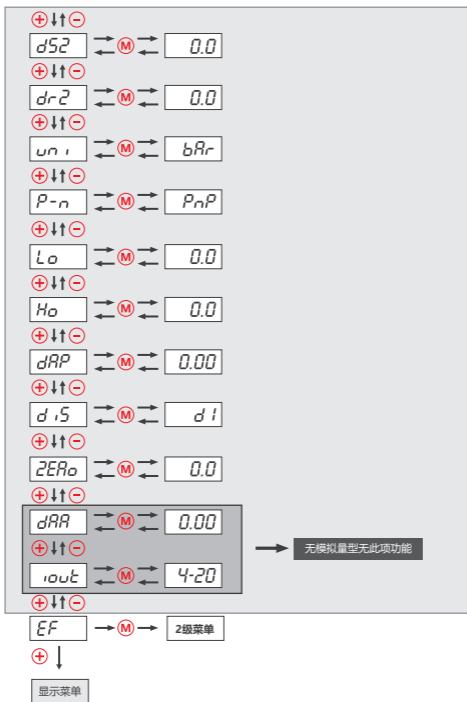

维护/清洗

传感器（开关）不需要维护。



警告

定期检查开关是否正常工作。
如果开关不能正常工作，立即停止操作。



谨慎

使用不适当的清洗剂可能会损坏开关。
下列清洗剂可用于清洗聚碳酸酯：温和的肥皂或洗涤剂
异丙醇
清洗后，立即用清水冲洗。不要将清洁剂留在产品表面。不要在高温或阳光直射下清洁产品。
下列清洗剂已知会影响聚碳酸酯组件的完整性，不应使用：ZEP Fast 505, Pinesol, 公式409
卤代溶剂(苯、汽油、丙酮或四氯化碳)
强碱性
甲乙酮
研磨物质

拆卸



危险

只有在断电时(电、液压/气动)才拆下开关。
开关与压力和电源的断开必须由经过培训或指导的人员按照最先进的标准进行。



警告

请注意，如果操作温度较高，壳体表面可能会变得非常热!



Name of Reliability in Quality Accessories