

Pressure Reducing Valve (Direct Operated) Manual

USE:

This product reduces the pressure of the medium in equipment and pipelines to a required outlet pressure by adjustment. It relies on the energy of the medium itself to maintain a stable outlet pressure automatically.

TECHNICAL PARAMETERS:

- **Nominal Pressure** : 1.6Mpa
- **Medium**: Water
- **Working Temperature**: $0^{\circ}\text{C} < t \leq 80^{\circ}\text{C}$
- **Maximum Inlet Pressure**: 1.6Mpa
- **Adjustable Outlet Pressure Range**: 0.10~0.30MPa
- **Factory Set Outlet Pressure**: 0.2Mpa

STRUCTURE AND PERFORMANCE CHARACTERISTICS:

1. This product is a filter-type adjustable pressure reducing valve, utilizing a diaphragm and spring as sensitive components. Special consideration has been given to the stability of the valve disc's movement. The use of high-quality wear-resistant materials and superior processing technology ensures smooth operation of the parts.
2. Water-related components are made from bronze and 304 materials, in compliance with **AS/NZS 4020:2005**.
3. All rubber components are made from EPDM rubber, ensuring reliable static pressure reduction. This product is particularly suitable for large flow and large diameter pipeline systems, offering stable operation, reliable sealing, long service life, and excellent outlet pressure stability.

INSTALLATION:

1. The arrow on the valve body indicates the direction of the medium flow. During installation, ensure the inlet and outlet are correctly oriented; otherwise, the pressure reducing valve will not operate properly, and valve parts may be damaged.
2. The product should be installed on a level surface. It is recommended to install a filter at the valve's inlet to remove impurities.
3. The import and export of this product are pre-equipped with pressure gauge interfaces. A pressure gauge is provided with the product when leaving the factory.
4. This product is compatible with pressure gauges that have a G 1/4" connecting thread.

PIPE LINE:

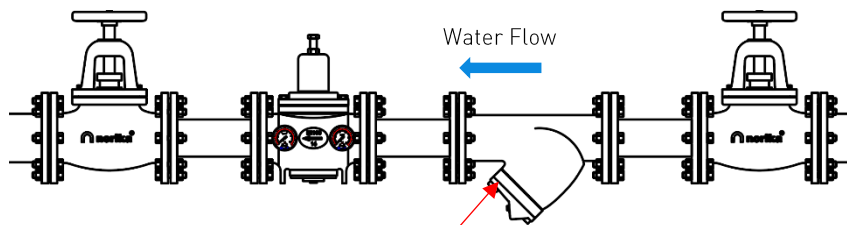

Note: A strainer must be installed before the pressure reducing valve to prevent damage from debris.

PRESSURE ADJUSTMENT GUIDE:

1. **To increase the outlet pressure:** Rotate the hexagonal bolt clockwise (Figure No. 1).
2. For the initial water pressure test, first increase the outlet pressure and flush the pipeline to remove any debris and air present.
3. After setting the pressure, tighten the hex nut on top of the upper valve cover to lock the hexagonal bolt in place.

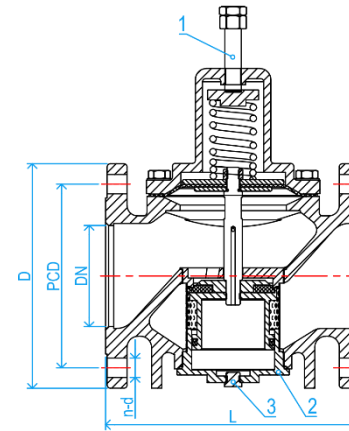

SKU	DN	PCD	D	L	n-d
PRVCRN080F	80	160	200	225	8-18
PRVCRN100F	99	180	220	250	8-18
PRVCRN150F	148	240	285	308	8-22

☆ When discharging water, it is necessary to unscrew the bottom cover labeled with serial number 3.

☆ When cleaning the valve, it is necessary to unscrew the valve cover labeled with number 2 and clean the filter screen.

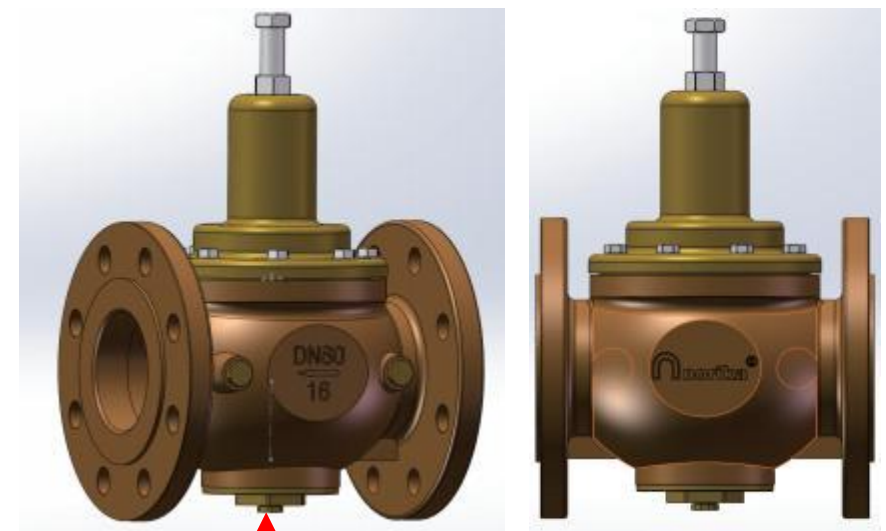

The minimum height for installation from the ground or wall is 200mm.

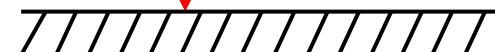

法兰式减压阀说明书

一、用途

本产品通过调节，将设备和管路内的介质压力减至某一需要的出口压力，并依靠介质本身的能量使出口压力自动保持稳定。

二、技术参数

1. 公称压力：1.6MPa；
2. 工作介质：水；
3. 工作温度：0 C° < t ≤ 80C° ；
4. 最高进口压力：1.6MPa；
5. 出口压力可调范围：0.10~0.30MPa；
6. 出厂设定出口压力：0.2MPa；

三、结构和性能特点：

1. 本产品是一种过滤型可调式减压阀，用膜片和弹簧作为敏感元件，设计中特别考虑阀瓣的升降的稳定性。本产品采用优质耐磨材料和良好的加工工艺，确保零件工作平稳。
2. 涉水零件采用青铜和304材质，以符合AS/NZS 4020:2005 。
3. 所有橡胶件采用EPDM橡胶，确保可靠的静态减压。本产品特别适用大流量大口径管路系统，工作平稳，密封可靠寿命长，出口压力稳定性好。

四、安装：

1. 阀体所示箭头是介质流动方向。安装时进出口不能倒接，否则减压阀不能打开，还要损坏阀门零件。
2. 本产品需水平，建议在阀门入口端安装过滤器去除杂质。
3. 本产品进出口预设安装压力表接口。出厂时本产品配备压力表。
4. 本产品适用如下规格压力表：连接螺纹为G1/4”。

管道线路：

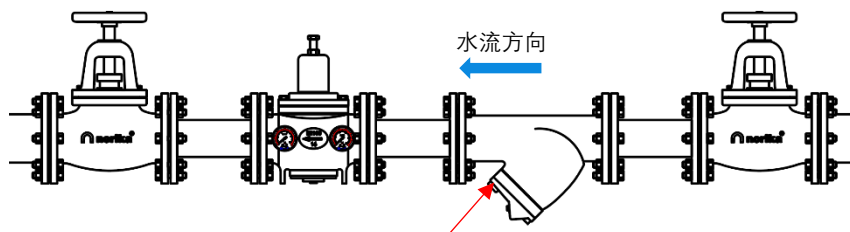

注意：减压阀前必须安装过滤器，以防止残渣杂质造成损坏。

五、调压：

1. 出口压力调高：顺时针旋转六角螺栓（图 序号1），
2. 出口压力调低：逆时针旋转六角螺栓。
3. 初次通水试压，应先调高出口端压力，进行冲洗，排除管路内可能存在的杂物与空气。
4. 压力调定后，将六角螺母并紧在上阀盖顶端，以锁定六角螺栓。

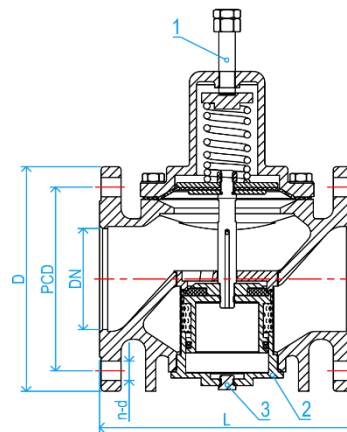

型号规格	DN	PCD	D	L	n-d
PRVCRN080F	80	160	200	225	8-18
PRVCRN100F	99	180	220	250	8-18
PRVCRN150F	148	240	285	308	8-22

☆ 排污水时，需旋出序号3底盖；

☆ 清洗阀门时，需旋出序号2下阀盖，并清洗过滤网。

