

TWO WAY VALVE (FOR BATHROOM)

COMPLY WITH :BS EN 13828:2003
AS/NZS 4020:2005
SS375:2015
SS270:2015
BS EN 12165:2016

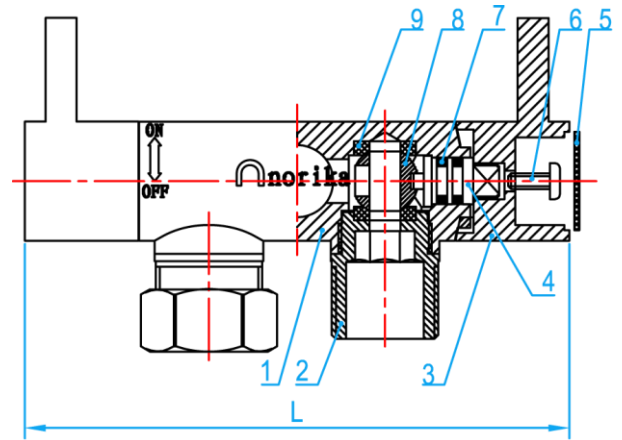
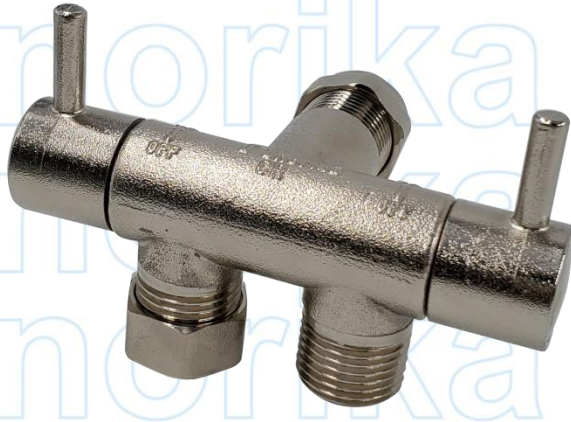
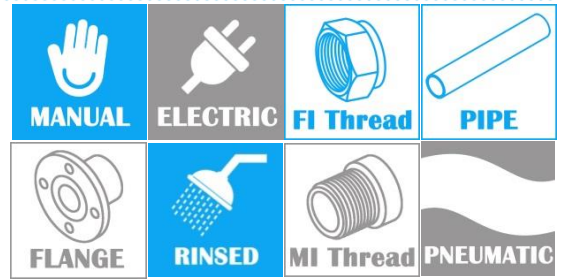

SECTION VIEW

COMPONENT PARTS

ITEM	PARTS	MATERIAL
1	Body	DZR Brass
2	Bonnet	DZR Brass
3	Handle	Kirsite
4	Stem	DZR Brass
5	Decorative cover	ABS
6	Screw	AISI304
7	O-ring	EPDM
8	Ball	DZR Brass
9	Seat	PTFE
10	Nut	DZR Brass
11	Ring	Brass
12	End Cap	DZR Brass
13	Washer	EPDM

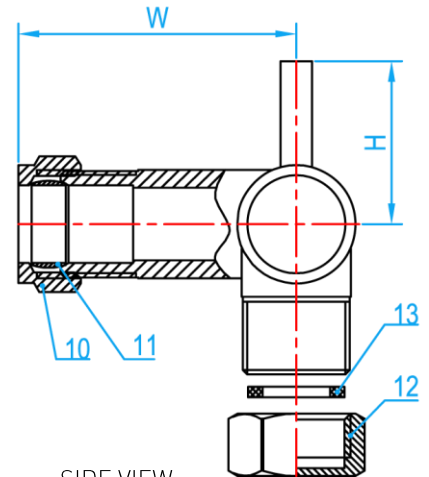

SIDE VIEW

STANDARD SPECIFICATIONS

Nominal pressure	1.0MPa
Working Medium	Water
Working Temperature	≤ 90 °C

SPECIFICATIONS

SKU	CONNECTOR (inch)	L (mm)	W (mm)	H (mm)	WEIGHT (Kg)	PCS/CTN
NJF772	1/2" BSP	105	53	31.5	0.342	60