

DUCTILE IRON UNI-CHECK VALVE

COMPLY WITH BS5153:1974
BS6755:1986
AS/NZS4020:2005

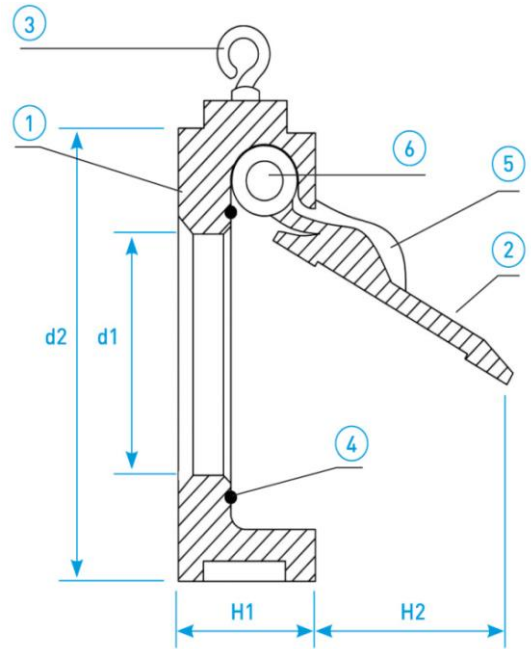

CROSS SECTIONAL VIEW

STANDARD SPECIFICATIONS

Nominal Pressure	PN16
Sealing Test Pressure	1.76Mpa
Strength Test Pressure	2.4Mpa
Operating Temperature	-10 ~ 120°C

DIMENSIONS

SKU	SIZE (mm)	d2 (mm)	H1 (mm)	d1 (mm)	H2 (mm)	WEIGHT (kg)
CVDIU050	50	107	44.5	33.3	28.6	1.8
CVDIU065	65	127	47.6	42.9	30.2	2.4
CVDIU080	80	142	50.8	52.4	55.6	3.2
CVDIU100	100	162	57.2	76.2	74.6	5.4
CVDIU125	125	192	63.5	95.3	95.3	7.3
CVDIU150	150	218	39.9	114.3	114.3	9.2
CVDIU200	200	273	73.0	155.6	155.6	14.6
CVDIU250	250	328	79.4	187.3	187.3	23.6
CVDIU300	300	378	85.7	222.3	222.3	34.4

COMPONENT PARTS

ITEM	PARTS	MATERIAL
1	Body	Ductile Iron
2	Clapper Plate	AISI304
3	Hanger	AISI304
4	Seal Ring	EPDM
5	Spring	AISI304
6	Axle	AISI304