

DUCTILE IRON TWIN FOLD WAFFLE CHECK VALVE

COMPLY WITH BS 5153:1974
 BS EN 545:2010
 AS/NZS 4020:2005
 SS 375:2015
 SS 270: 2015

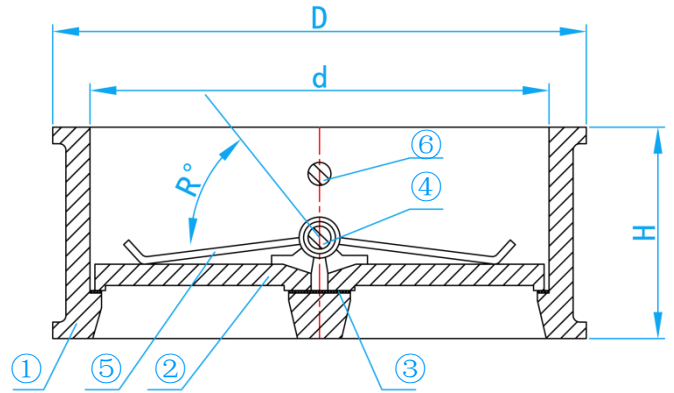
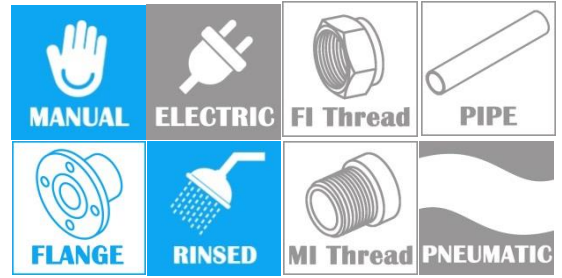

CROSS SECTIONAL VIEW

STANDARD SPECIFICATIONS

Nominal Pressure	PN16
Sealing Test Pressure	1.76Mpa
Strength Test Pressure	2.4Mpa
Operating Temperature	-10 ~ 120°C

COMPONENT PARTS

ITEM	PARTS	MATERIAL
1	Body	Ductile Iron
2	Plate	Stainless Steel AISI304
3	Bonnet Gasket	EPDM
4	Turning Axle	Stainless Steel AISI304
5	Spring	Stainless Steel AISI304
6	Shaft	Stainless Steel AISI304

DIMENSIONS

SKU	SIZE (mm)	D (mm)	d (mm)	H (mm)	R° [mm]	WEIGHT (kg)
CVDIN080	80	142	94	64	43.4°	2.8
CVDIN100	100	162	117	64	52.8°	4.1
CVDIN150	150	218	170	76	78.6°	8.5
CVDIN200	200	273	224	89	88°	13.5
CVDIN250	250	328	265	114	88°	22.0
CVDIN300	300	384	312	114	88°	30.0