

DOUBLE CHECK VALVE

COMPLY WITH BS5154:1991
BSEN1254-2:1998

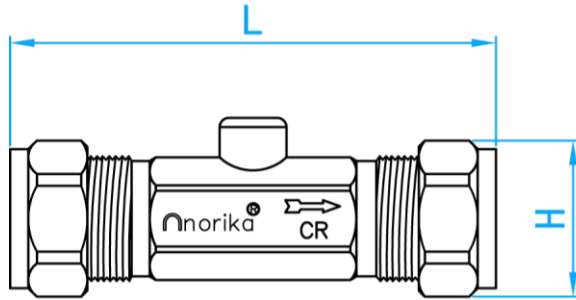

FRONT VIEW

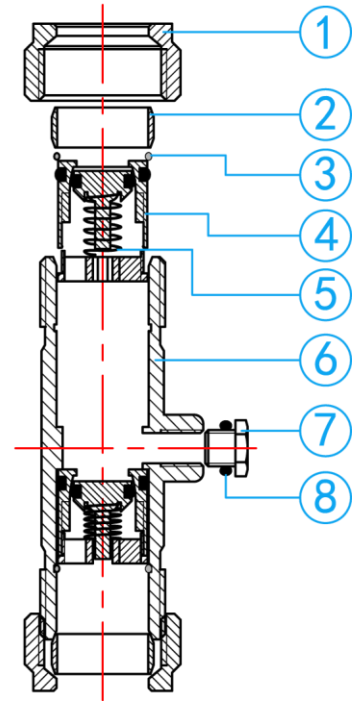

CROSS SECTIONAL VIEW

STANDARD SPECIFICATIONS

Working Pressure	200Psi
Applicable Medium	Water

DIMENSIONS

SKU	SIZE (mm)	L (mm)	H (mm)	WEIGHT (kg)	PCS/CTN
DCVCRN015	15	79	31.1	0.105	180
DCVCRN020	20	83	40	0.213	100

COMPONENT PARTS

ITEM	PARTS	MATERIAL
1	Compression Nut	Brass
2	Compression Ring	Brass
3	Ring	AISI304
4	Spool	ABS
5	Spring	AISI304
6	Body	DZR Brass
7	Nut	Brass
8	Seat	NBR