

BRASS SPRING CHECK VALVE F x F

COMPLY WITH BS 5154:1991
 AS/NZS 4020:2005
 SS 375:2015
 BS EN 12165:2011
 SS 270:2015

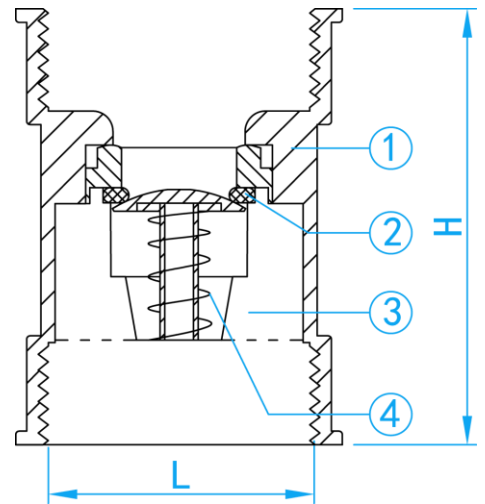
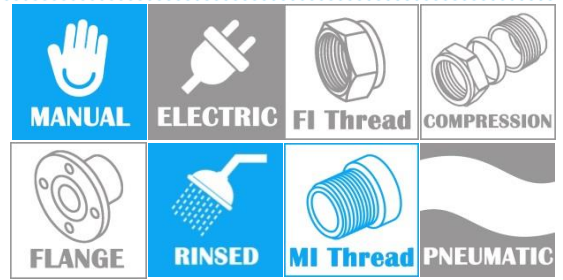

CROSS SECTIONAL VIEW

STANDARD SPECIFICATIONS

Working Pressure	200 Psi
Applicable Medium	Water

DIMENSIONS

SKU	SIZE (mm)	H (mm)	L (inch)	WEIGHT (kg)	PCS/CTN
CVCRN015	15	41	½" BSP	0.092	240
CVCRN020	20	46	¾" BSP	0.100	200
CVCRN025	25	54	1" BSP	0.176	120
CVCRN035	35	64	1¼" BSP	0.235	80
CVCRN042	42	78	1½" BSP	0.315	65
CVCRN050	50	83	2" BSP	0.375	25

COMPONENT PARTS

ITEM	PARTS	MATERIAL
1.	Body	DZR Brass
2.	O-ring	NBR
3.	Piston	POM
4.	Spring	AISI304