

FUSION BONDED EPOXY COATED HUBLESS BRANCH TEE 88°

COMPLY WITH EN877:2010 01

*Availability upon request

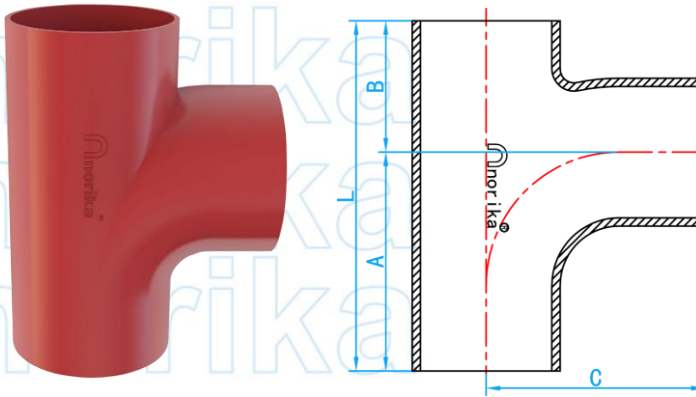

CROSS SECTIONAL VIEW

COATING CHARACTERISTIC

Fittings:

 Epoxy fittings inside and outside:
Fusion bonded epoxy coating.

Coating Thickness: Min- 240µm

DIMENSIONS

SKU	DN (mm)	A (mm)	B (mm)	L (mm)	C (mm)	WEIGHT (kg)
HUBET050EPC	50X50	79	66	145	80	0.9
HUBRT08050EPC	75X50	95	85	180	90	1.6
HUBET080EPC	75X75	95	85	180	90	1.9
HUBRT10050EPC	100X50	94	76	170	105	2.1
HUBRT10080EPC	100X75	105	90	195	110	2.6
HUBET100EPC	100X100	115	105	220	120	2.9
HUBRT12550EPC	125X50*	98	82	180	120	3.0
HUBRT12580EPC	125X75*	110	94	205	125	3.4
HUBRT125100EPC	125X100*	125	110	235	130	4.0
HUBRT15050EPC	150X50	100	100	200	140	4.4
HUBRT15080EPC	150X75	110	110	220	145	5.0
HUBRT150100EPC	150X100	130	115	245	145	5.5
HUBRT150125EPC	150X125*	147	128	275	150	6.2
HUBET150EPC	150X150	158	142	300	155	6.9
HUBRT200100EPC	200X100	144	126	270	175	7.8
HUBRT200150EPC	200X150	173	152	325	185	10.8
HUBET200EPC	200X200	202	178	380	195	12.8
HUBRT250100EPC	250X100	165	147	312	210	18.2
HUBRT250150EPC	250X150	195	160	355	230	19.3
HUBRT250200EPC	250X200	205	200	405	240	21.0
HUBET250EPC	250X250	250	220	470	240	24.5
HUBET300EPC	300X300	300	266	566	300	38.0