

FUSION BONDED EPOXY COATED HUBLESS SHORT PIPE WITH ACCESS DOOR & BEND & CROSS TEE

COMPLY WITH EN877:2010 01

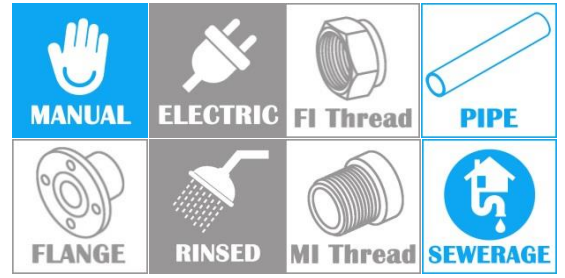

COATING CHARACTERISTIC

Fittings:

Epoxy fittings inside and outside: Fusion bonded epoxy coating.

Coating Thickness: Min- 240µm

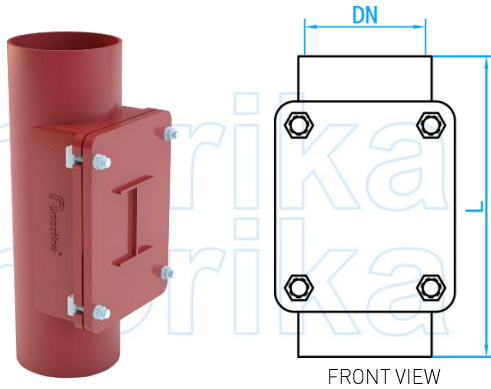

SHORT PIPE WITH ACCESS DOOR

DIMENSIONS

SKU	DN (mm)	L (mm)	WEIGHT (kg)
HUBSP080EPC	75	220	2.3
HUBSP100EPC	100	340	7.6
HUBSP150EPC	150	395	14.5
HUBSP200EPC	200	465	22.0
HUBSP250EPC	250	575	36.5

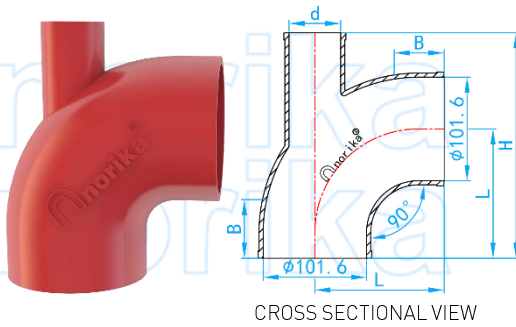

4"x2"X90 DEG BEND

DIMENSIONS

SKU	SIZE (mm)	B (mm)	L (mm)	d (mm)	H (mm)	WEIGHT (kg)
HUBB9010050EPC	100X50	35	125	50.8	218	2.50



CROSS TEE 88°

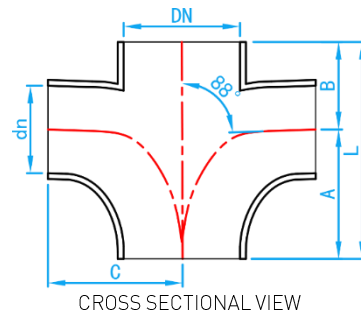

DIMENSIONS

SKU	DN (mm)	dn (mm)	A (mm)	B (mm)	L (mm)	C (mm)	WEIGHT (kg)
HUBCT10050EPC	100	50	100	80	180	105	2.2
HUBCT100100EPC	100	100	120	110	230	120	3.2
HUBCT150100EPC	150	100	130	115	245	145	7.1