

DUCTILE IRON SWING CHECK VALVE

COMPLY WITH BS5153: 1974

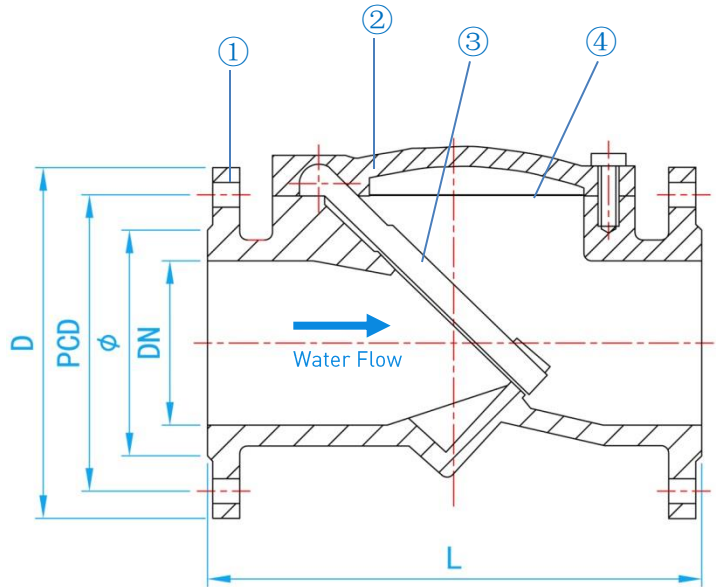
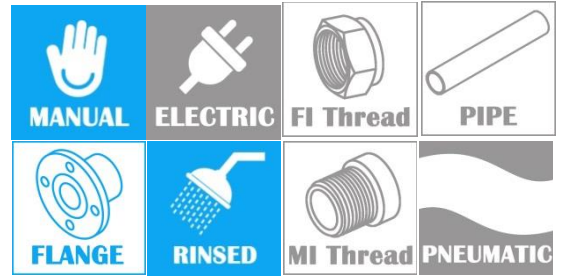

CROSS SECTIONAL VIEW

STANDARD SPECIFICATIONS

Nominal Pressure	PN16
Sealing Test Pressure	1.76 Mpa
Strength Test Pressure	2.4 Mpa
Opening inlet Pressure	≥ 0.5 Bar
Close The Leak Free Pressure	2 Bar
Operating Temperature	0 ~ 80°C

COMPONEN PARTS

ITEM	PARTS	MATERIAL
1	Body	Ductile Iron
2	Bonnet	Ductile Iron
3	Disc	Steel, EPDM
4	Gasket	EPDM

DIMENSIONS

SKU	DN (mm)	L (mm)	D (mm)	PCD (mm)	Ø (mm)	WEIGHT (Kg)
SCVDIN080	80	241	195	160	132	12
SCVDIN100	100	292	215	180	156	17
SCVDIN150	150	356	280	240	211	34
SCVDIN200	200	495	335	295	266	53
SCVDIN250	248	550	400	355	319	70
SCVDIN300	300	698	455	410	370	98
SCVDIN400	390	730	580	525	489	173
SCVDIN500	495	860	715	650	609	286