

# DUCTILE IRON TWIN FOLD WAFFLE CHECK VALVE

COMPLY WITH BS5153:1974  
BSEN545:2006  
AS/NZS4020:2005

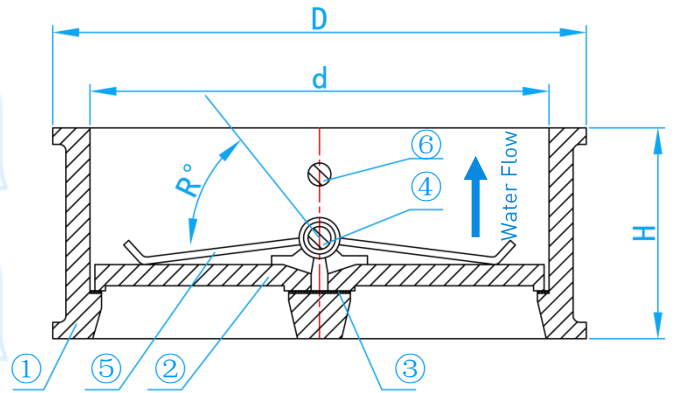

CROSS SECTIONAL VIEW

## STANDARD SPECIFICATIONS

Nominal Pressure	PN16
Sealing Test Pressure	1.76Mpa
Strength Test Pressure	2.4Mpa
Operating Temperature	-10 ~ 120°C

## COMPONENT PARTS

ITEM	PARTS	MATERIAL
1	Body	Ductile Iron
2	Plate	Stainless Steel AISI304
3	Bonnet Gasket	EPDM
4	Turning Axle	Stainless Steel AISI304
5	Spring	Stainless Steel AISI304
6	Shaft	Stainless Steel AISI304

## DIMENSIONS

SKU	SIZE (mm)	D (mm)	d (mm)	H (mm)	R° [mm]	WEIGHT (kg)
CVDIN080	80	142	94	64	43.4°	2.8
CVDIN100	100	162	117	64	52.8°	4.1
CVDIN150	150	218	170	76	78.6°	8.5
CVDIN200	200	273	224	89	88°	13.5
CVDIN250	250	328	265	114	88°	22.0
CVDIN300	300	384	312	114	88°	30.0